

VINCKE HYDRAULICS

GEAR PUMPS

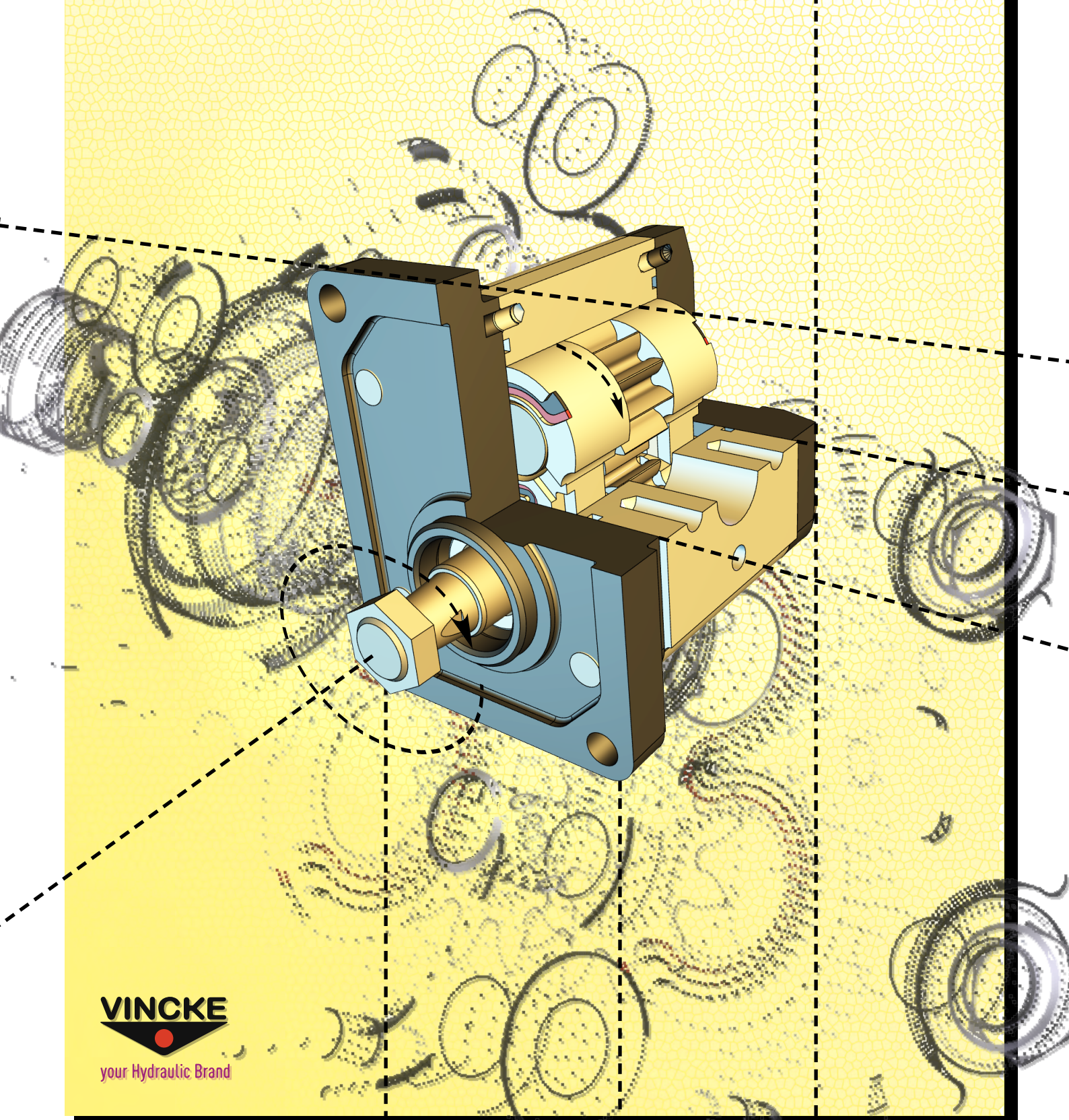

VINCKE
your Hydraulic Brand

Index

.....	3
.....	6
.....	8
.....	9
.....	10
.....	11
.....	12
.....	14
.....	15
.....	16
.....	17
.....	18
.....	19
.....	20
.....	21
.....	22
.....	25
.....	26
.....	27
.....	28
.....	30
.....	31
.....	32
.....	33
.....	35
.....	37
.....	39
.....	41
.....	42
.....	47

INTRODUCTION

Gear pumps from Vincke have a floating bushing feature with automatic axial clearance compensation. The bushings are made with special abrasion resistant material providing improved service life. Precisely machined gears ensure our units provide excellent low noise characteristics. Our cold extrusion motor bodies can endure pressures above 30Mpa. High strength cast iron front & rear covers also enhance our reliability. Our units are widely used in the industrial, mobile, marine and aerospace industries.



CHARACTERISTICS

Vincke gear pumps are produced in 5 different versions (G0, G1, 2P, 2.5P, 3P), and in each group different displacements are obtained by changing the gears width.

- Pressure: VINCKE offers one pressure rating, please refer to charts.
- Efficiencies: volumetric up to 98%, mechanical up to 93%.
- Mountings: flanges, shaft ends and ports.
- Seals: Viton seals available.
- Integrate: all pumps can be ordered with relief valve and check valve.

Peak	up to 30Mpa	max. 3 sec.
Intermittent	up to 28Mpa	max. 25 sec.
Rated	up to 25 Mpa	

HYDRAULIC FLUIDS

Use specific mineral oil based hydraulic fluids having good antioxidant, anti-foaming (rapid de-aeration), anti-wear, anti-corrosion and lubricating properties, Fluids should also comply with DIN 51525 and VDMA 24317 standards and gel through 11th stage of FZG test.

For the standard models, the temperature of the fluid should range between 1°C and 80°C.

Fluid kinematic viscosity ranges are the following:

Allowed Range	6 ... 500 cSt
Recommended Range	1 ... 100 cSt
Value allowed at startup	... 2000 cSt

- Place safety relief valve set at correct pressure and with good dynamic characteristic.
- Recommended fluid speed in the inlet line—1.6-5ft/s (0.5-1.5m/s).
- Recommended fluid speed in the delivery line—6.5-20ft/s (2-6m/s).
- Recommended fluid speed in the return line—5-10ft/s (1.5-3m/s).
- Reservoir should have a capacity about twice as much as the volume of delivered by the pump in one minute.
- The return and inlet pipe must be separated as far as possible and under the minimum level of the oil.
- Install pump in a well cleaned environment, and make sure, prior starting the system that all pipes and reservoir are perfectly clean it is recommended to filter the new oil at 8-10um, before filling the reservoir.
- Fill the pump with fluid before installing and check the direction of rotation.
- Avoid sharp restrictions and small radius bends.
- For the first run of the pump, it is advisable to disconnect the pump discharge in order to purge the air from the system.

FILTER RECOMMENDATION

- By far largest number of premature failures of gear pumps is due to contamination; filtering with clogging indicating and alarms are recommended.
- The initial contamination of the fluid must not exceed class 10 NAS 1638, pass experience has shown that even brand new fluid often exceeded this value in this case it is recommended below: 60µm inlet, and in the return side:

Standard	P<2000PSI(14MPa)	2000PSI(14MPa)<P<3050PSI(21MPa)	P>3050PSI(21MPa)
NAS1638	10	9	8
ISO4406	19/16	18/15	17/14
FILTER	25µm	20µm	10µm

PRESSURE DEFINITION

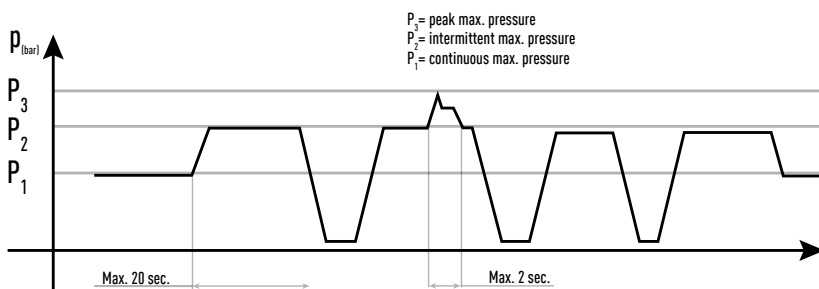

INLET PRESSURE

Under standard working conditions, intake pipe pressure is lower than atmospheric pressure. The operating inlet pressure should range between 0.7 and 3 bars (absolute).

ROTATION DIRECTION

Definition of rotation direction: When standing before the pump with driving shaft up with its projecting end towards the observer, the pump is rotating clockwise in case of right-hand rotation "C". The contrary will happen with left-hand pumps "A", keeping the same point of view.

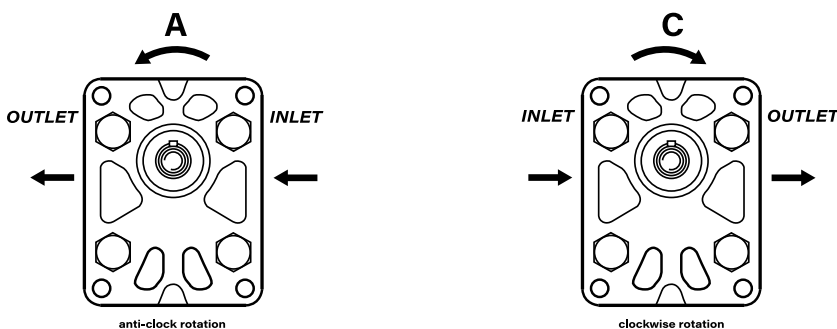

INLET AND DELIVERY LINES

Intake lines	0,5 ... 1,6 m/s
Delivery line	2 ... 6 m/s
Return line	1,6 ... 3 m/s

DESIGN CALCULATIONS FOR PUMP

Q = flow rate (l/m)

M = torque

P = power

N = speed r/min

A = inside area of pipe (cm²)

v = $Q / 6 \cdot A$ (m/s)

V = displacement [cm³/rotation]

n = rotation speed [rotations per minute]

η_{vol} = pump volumetric efficiency, take 0.95 as an indicative value for rotation speeds ranging between 1.000 and 2000 rpm.

ΔP = pressure differential (bar)

η_{hm} = hydromechanical efficiency, take 0.80 as indicative value under cold conditions and 0.85 under working conditions.

η_{tot} = total pump efficiency (η_{hm} · η_{vol})

Fluid velocity

Calculate the velocity (v) of a fluid in a pipe as bellow:

$$v = Q / 6 \cdot A \text{ (m/s)}$$

Delivered flow rate

Calculate flow rate (Q) as bellow:

$$Q = V \cdot n \cdot \eta_{vol} \cdot 10^{-3} \text{ (L/min)}$$

Absorbed torque

Calculate necessary torque (M) of a pump subject to pressure differential between inlet and delivery as bellow:

$$M = (V \cdot \Delta p) / (62,8 \cdot \eta_{hm}) \text{ (Nm)}$$

Absorbed power

Calculate hydraulic power (P) transferred to fluid from a pump subject to a pressure differential between inlet outlet and delivery as bellow:

$$P = (q \cdot \Delta p) / (612 \cdot \eta_{tot}) \text{ (kW)}$$

Values for η_{vol} and η_{hm}, and consequently η_{tot} depend on pressure differential between inlet outlet and delivery, rotation speed, fluid features (temperature and viscosity) and filtering degree.

VNKO GEAR PUMP GROUP 0

End cover: G1 / 4 thread depth 12. To mount the pump, n.2 M5 screws, with a torque wrench setting fixed at 5.4 ± 0.5 Nm.



HOW TO ORDER

Single pump	Group	Size	Shaft	Flange	Inlet port	Outlet port	Rotation	
VNKB	0,5	0.19	01	B	38	OR	C	Clockwise
		0.25					A	Counter clockwise
		0.38						
		0.5						
		0.75						
		1.00						
		1.25						
		1.5						
		1.75						
		2						

INLET

OUTLET

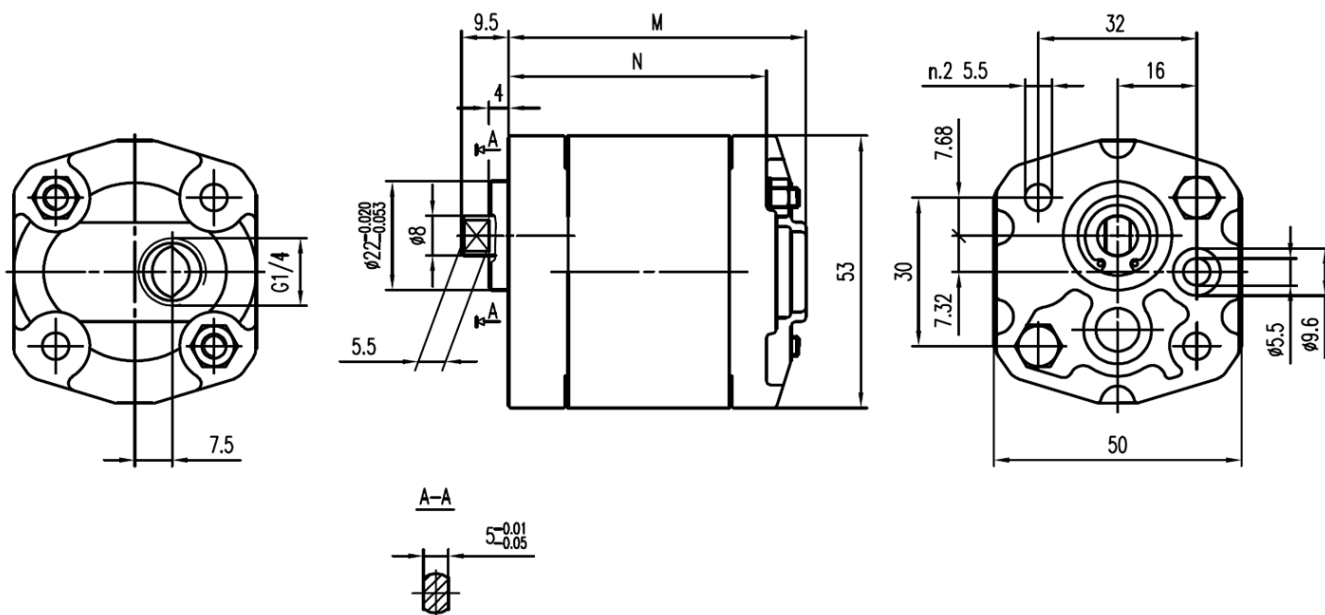

Type	Displacement cm ³ /rev	Max. Pressure			Max. Speed r/min	Min. Speed r/min	Dimensions	
		P1	P2	P3			M	N
		mm	mm	mm			mm	mm
VNK-0-019-01-02-B-38-OR-	0.19	200	230	250	7000	1000	60	58.2
VNK-0-025-01-02-B-38-OR-	0.25	200	230	250	7000	1000	60,5	59
VNK-0-038-01-02-B-38-OR-	0.38	200	230	250	7000	1000	61,5	60.3
VNK-0-050-01-02-B-38-OR-	0.5	200	230	250	7000	1000	62,5	61
VNK-0-065-01-02-B-38-OR-	0.65	200	230	250	7000	1000	63,5	54,5
VNK-0-075-01-02-B-38-OR-	0.75	200	230	250	7000	1000	64,5	63,5
VNK-0-088-01-02-B-38-OR-	0.88	200	230	250	7000	1000	65,5	56,5
VNK-0-1-01-01-02-B-38-OR-	1,00	200	230	250	6000	850	66,5	66
VNK-0-1.25-01-02-B-38-OR-	1.25	200	230	250	500	700	68,5	68.5
VNK-0-1.5-01-02-B-38-OR-	1.5	200	230	250	400	600	70,5	70
VNK-0-1.75-01-02-B-38-OR-	1.75	180	210	230	4000	600	72,5	73
VNK-0-2-01-02-B-38-OR-	2	160	190	210	3000	500	74,5	75.5

VNK1 GEAR PUMP GROUP 1

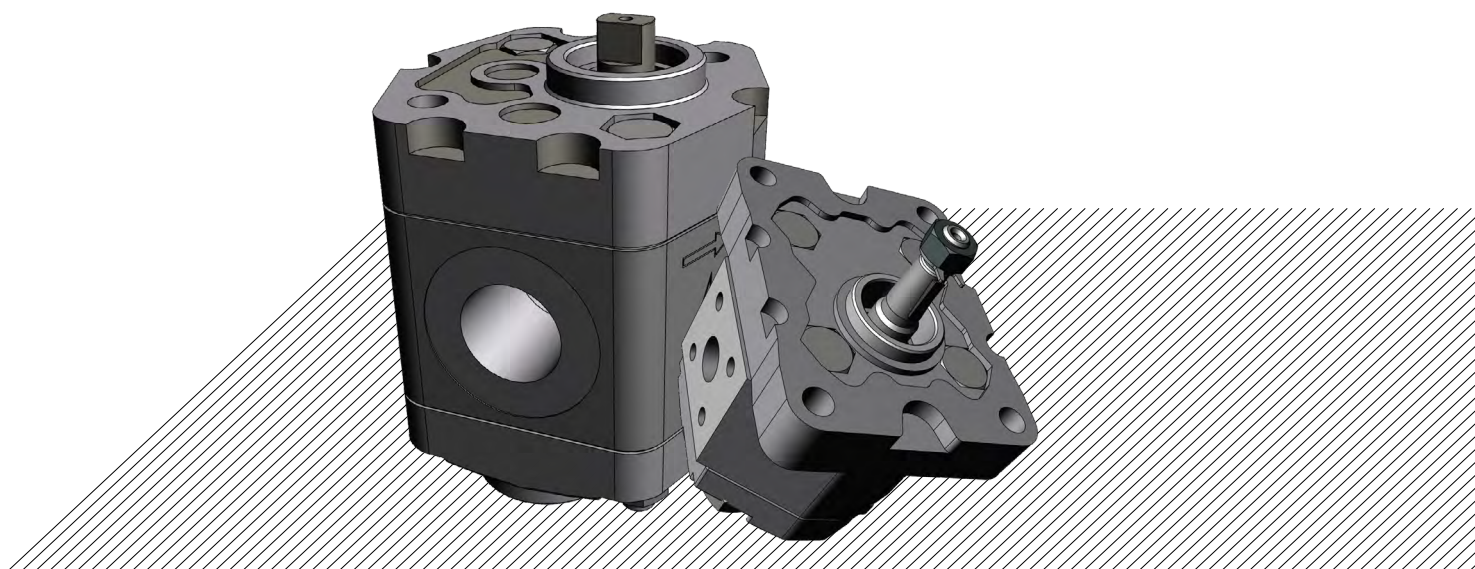

HOW TO ORDER

Single pump	Group	Size	Shaft *	Flange *	Inlet port *	Outlet port *	Rotation				
VNKB	1	0.8					<table border="1"> <tr> <td>C</td> <td>Clockwise</td> </tr> <tr> <td>A</td> <td>Counter clockwise</td> </tr> </table>	C	Clockwise	A	Counter clockwise
		C						Clockwise			
		A						Counter clockwise			
		1.1									
		1.3									
		1.6									
		1.8									
		2.1									
		2.7									
		3.2									
		3.7									
		4.2									
		5									
		5.8									
7											
8											
9.8											

* see specifications of shafts, flanges and ports in pages 12, 13.

VNK1-*-02-B-38-OR

End cover: G3/8 thread depth 12. To mount the pump, n.2 M8 screws, with a torque wrench setting fixed at 27±3 Nrn.



INLET OUTLET

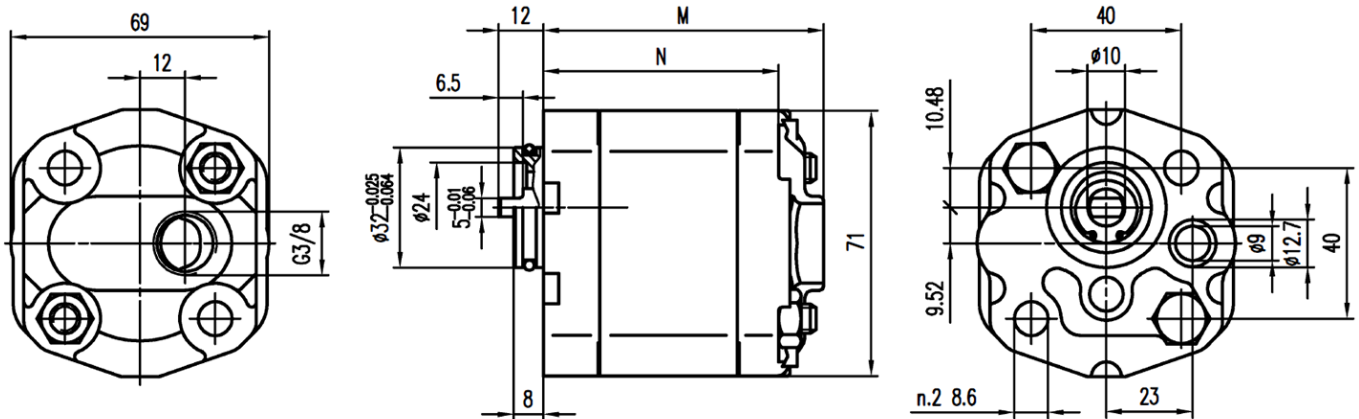

Type	Displacement cm ³ /rev	Max. Pressure			Max. Speed r/min	Min. Speed r/min	Dimensions	
		P1	P2	P3			M	L
		mm	mm	mm			mm	mm
VNK-1-0.8-02-B-38-OR-	0.8	250	270	290	6000	1000	73.5	61,5
VNK-1-1.1-02-B-38-OR-	1.1	250	270	290	6000	1000	74	62
VNK-1-1.3-02-B-38-OR-	1.3	250	270	290	6000	1000	75	63
VNK-1-1.6-02-B-38-OR-	1.6	250	270	290	6000	1000	76	64
VNK-1-1.8-02-B-38-OR-	1.8	250	270	290	6000	1000	77	65
VNK-1-2.1-02-B-38-OR-	2.1	250	270	290	6000	1000	78	66
VNK-1-2.7-02-B-38-OR-	2.7	250	270	290	6000	800	80	68
VNK-1-3.2-02-B-38-OR-	3.2	250	270	290	5000	800	82	70
VNK-1-3.7-02-B-38-OR-	3.7	250	270	290	4500	800	84	72
VNK-1-4.2-02-B-38-OR-	4.2	250	270	290	4000	800	86	74
VNK-1-4.8-02-B-38-OR-	4.8	230	250	270	3500	600	88	76
VNK-1-5.8-02-B-38-OR-	5.8	230	250	270	3000	600	92	80
VNK-1-5.8-02-B-38-OR-	7	210	230	250	2500	600	96	84
VNK-1-8.0-02-B-38-OR-	8	180	200	230	2100	600	100	88
VNK-1-9.8-02-B-38-OR-	9.8	150	170	190	2100	600	104	92

VNK1-*-02-B-38-38

M6 threads depth 12. To mount the pump, n.2 M8 screws, with a torque wrench setting fixed at 27 ±3 Nm.

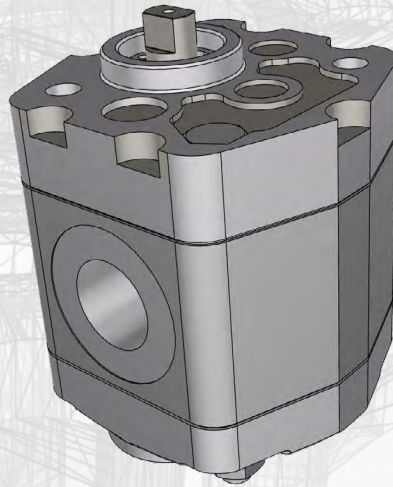

OUTLET

INLET

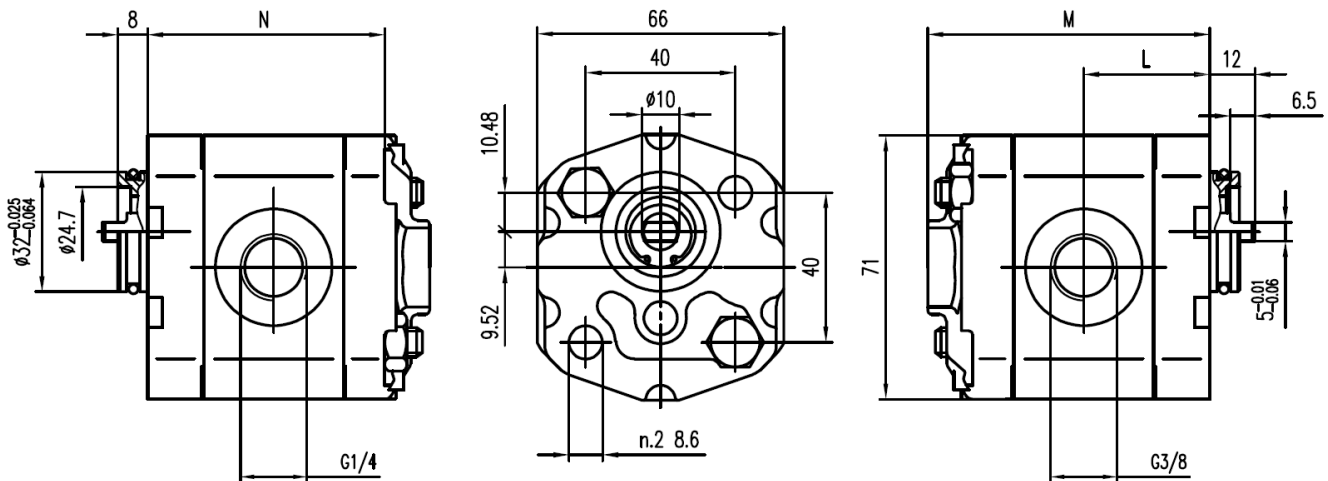

Type	Displacement cm ³ /rev	Max. Pressure			Max. Speed r/min	Min. Speed r/min	Dimensions		
		P1	P2	P3			M mm	N mm	L mm
VNK-1-0.8-02-B-38-38-	0.8	250	270	290	6000	1000	73.5	61.5	32.8
VNK-1-1.1-02-B-38-38-	1.1	250	270	290	6000	1000	74	62	33
VNK-1-1.3-02-B-38-38-	1.3	250	270	290	6000	1000	75	63	33.5
VNK-1-1.6-02-B-38-38-	1.6	250	270	290	6000	1000	76	64	34
VNK-1-1.8-02-B-38-38-	1.8	250	270	290	6000	1000	77	65	34.5
VNK-1-2.1-02-B-38-38-	2.1	250	270	290	6000	1000	78	66	35
VNK-1-2.7-02-B-38-38-	2.7	250	270	290	6000	800	80	68	36
VNK-1-3.2-02-B-38-38-	3.2	250	270	290	5000	800	82	70	37
VNK-1-3.7-02-B-38-38-	3.7	250	270	290	4500	800	84	72	38
VNK-1-4.2-02-B-38-38-	4.2	250	270	290	4000	800	86	74	39
VNK-1-4.8-02-B-38-38-	4.8	230	250	270	3500	600	88	76	40
VNK-1-5.8-02-B-38-38-	5.8	230	250	270	3000	600	92	80	42
VNK-1-5.8-02-B-38-38-	7	210	230	250	2500	600	96	84	44
VNK-1-8.0-02-B-38-38-	8	180	200	230	2100	600	100	88	46
VNK-1-9.8-02-B-38-38-	9.8	150	170	190	2100	600	104	92	48

VNK1-*1-1

M6 thread depth 12. To mount the pump, n.4 MB screws, with a torque wrench setting fixed at 27 ± 3 Nm.
 Shaft M7 nut, with a torque wrench setting fixed at 8 Nm.

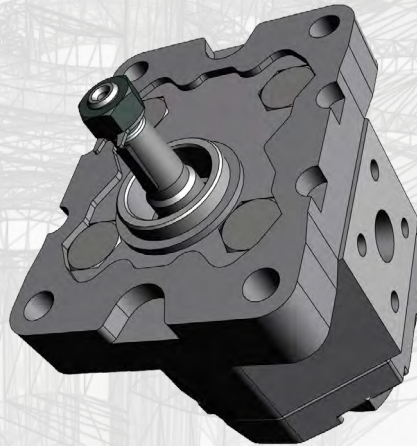

OUTLET

INLET

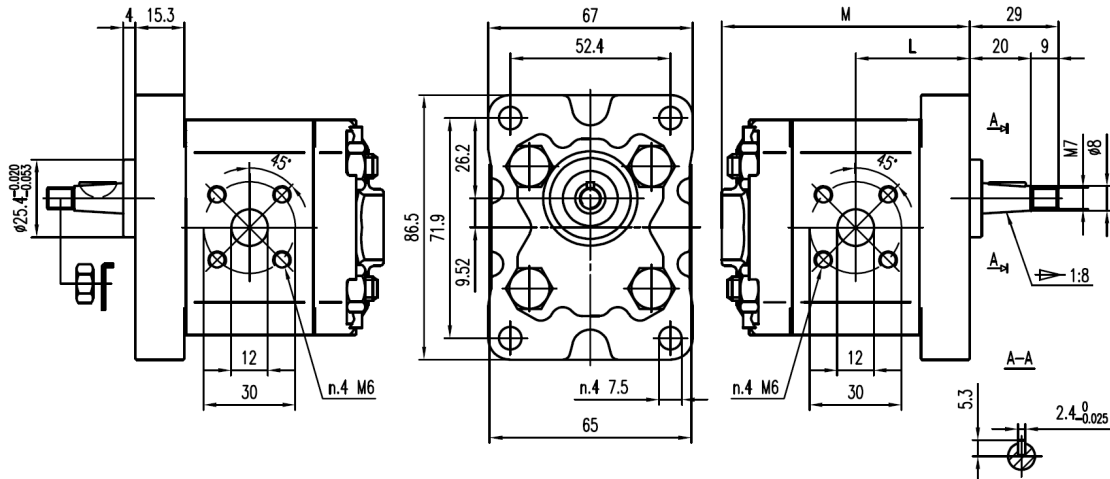

Type	Displacement cm ³ /rev	Max. Pressure			Max. Speed r/min	Min. Speed r/min	Dimensions	
		P1	P2	P3			M mm	L mm
VNK-1-0.8-1-1-*-*	0.8	250	270	290	6000	1000	73.5	32.8
VNK-1-1.1-1-1-*-*	1.1	250	270	290	6000	1000	74	33
VNK-1-1.3-1-1-*-*	1.3	250	270	290	6000	1000	75	33.5
VNK-1-1.6-1-1-*-*	1.6	250	270	290	6000	1000	76	34
VNK-1-1.8-1-1-*-*	1.8	250	270	290	6000	1000	77	34.5
VNK-1-2.1-1-1-*-*	2.1	250	270	290	6000	1000	78	35
VNK-1-2.7-1-1-*-*	2.7	250	270	290	6000	800	80	36
VNK-1-3.2-1-1-*-*	3.2	250	270	290	5000	800	82	37
VNK-1-3.7-1-1-*-*	3.7	250	270	290	4500	800	84	38
VNK-1-4.2-1-1-*-*	4.2	250	270	290	4000	800	86	39
VNK-1-4.8-1-1-*-*	4.8	230	250	270	3500	600	88	40
VNK-1-5.8-1-1-*-*	5.8	230	250	270	3000	600	92	42
VNK-1-7-1-1-*-*	7	210	230	250	2500	600	96	44
VNK-1-8-1-1-*-*	8	180	200	230	2100	600	100	46
VNK-1-9.8-1-1-*-*	9.8	150	170	190	2100	600	104	48

FRONT COVERS

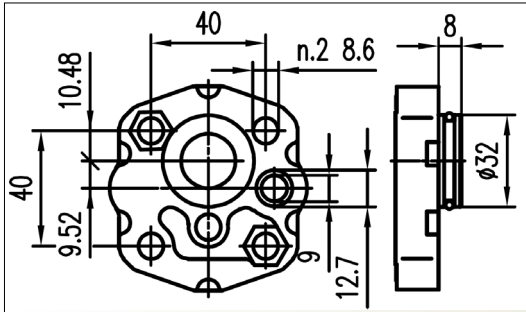

B

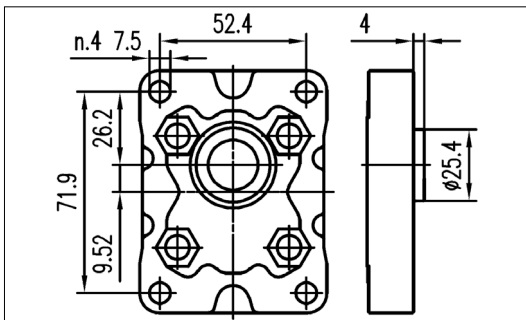

1

SHAFTS

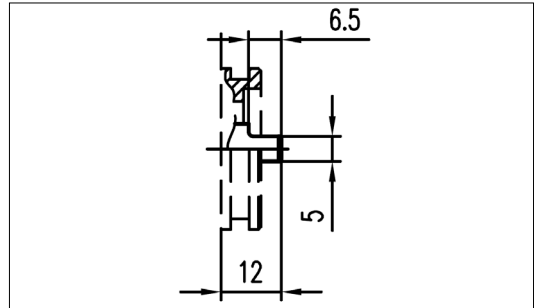

02

Max. Torque

20 Nm

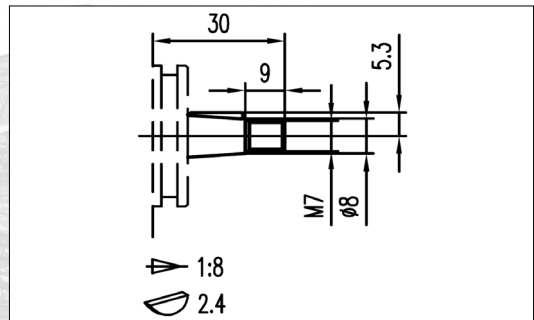

1

Max. Torque

20 Nm

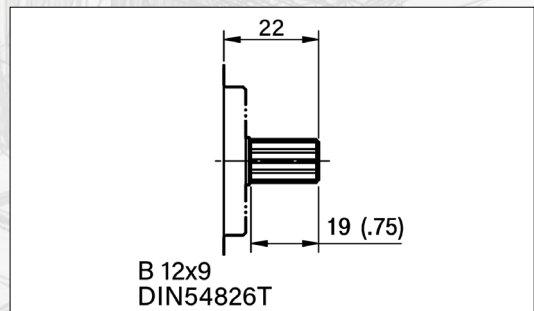

7

PORTS

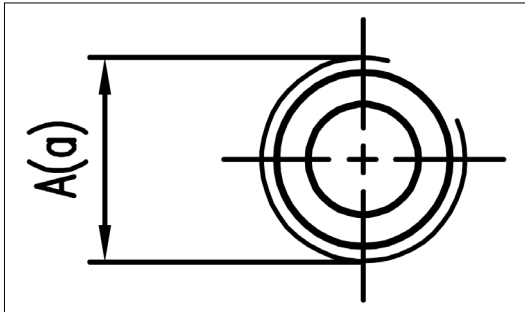

3838

INLET	OUTLET
A	a
G3/8	G3/8

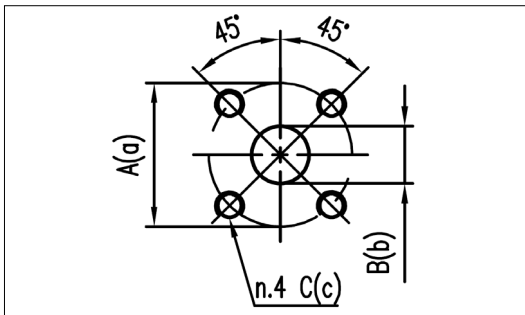

3030

INLET			OUTLET		
A	B	C	a	b	c
30	12	M6	30	12	M6

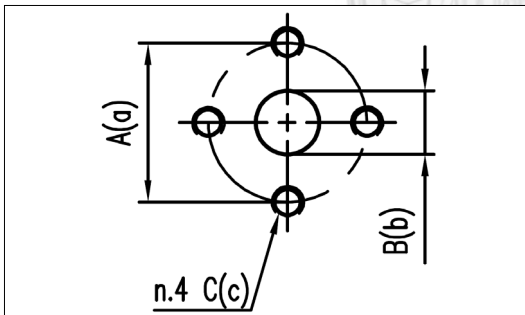

3030R

INLET			OUTLET		
A	B	C	a	b	c
30	12	M6	30	12	M6

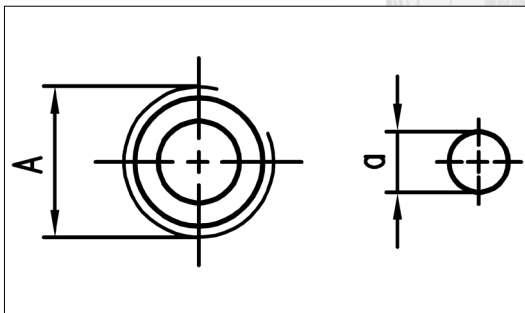

380R

INLET	OUTLET
A	a
G3/8	ø9

VNK2 GEAR PUMP GROUP 2

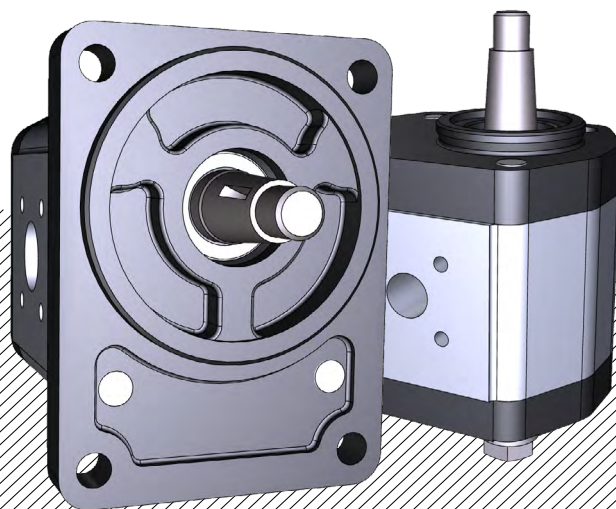

HOW TO ORDER

Single pump	Group	Size	Shaft *	Flange *	Inlet port *	Outlet port *	Rotation
VNKB	2	4	* see specifications of shafts, flanges and ports in pages 22, 23, 24				C
		6					A
		8					
		10					
		12					
		14					
		16					
		18					
		20					
		23					
		25					
		30					

VNK2-*-3-3-*

M6 thread depth 13, M8 thread depth 17. To mount the pump, n.4 M10 screws, with a torque wrench setting fixed at 70 ...W75 Nm. Shaft M 12x1.25 nut, with a torque wrench setting fixed at 50 Nm.



OUTLET

INLET

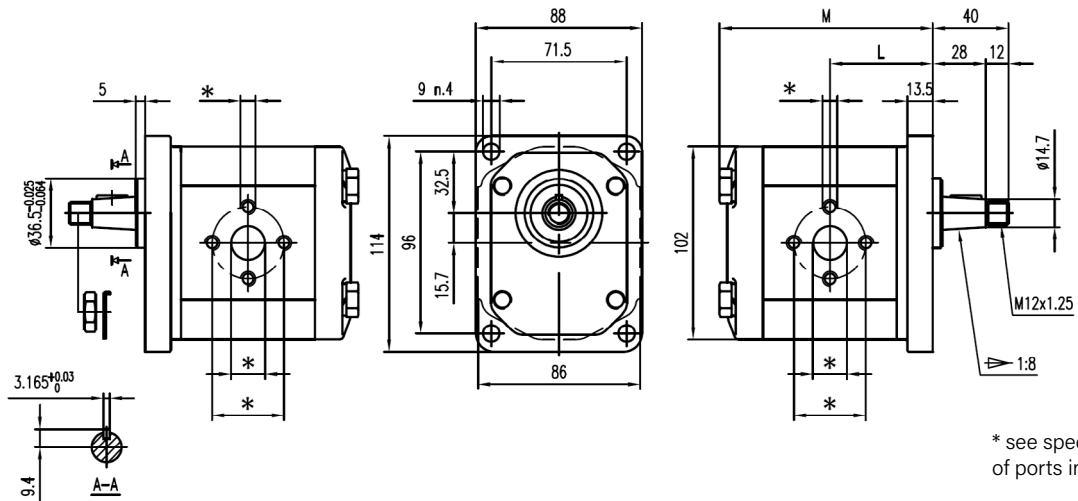

* see specifications of ports in page 29.

Type	Displacement cm ³ /rev	Max. Pressure			Max. Speed r/min	Min. Speed r/min	Dimensions	
		P1	P2	P3			M mm	L mm
VNK-2-4-3-3-*-*	4	270	285	300	4000	600	92,7	44,4
VNK-2-6-3-3-*-*	6	270	285	300	4000	600	96	46
VNK-2-8-3-3-*-*	8	270	285	300	3500	500	99,3	47,7
VNK-2-10-3-3-*-*	10	270	285	300	3000	500	102,6	49,3
VNK-2-12-3-3-*-*	12	270	285	300	3000	500	105,9	51
VNK-2-14-3-3-*-*	14	250	265	280	4000	500	109,3	52,7
VNK-2-16-3-3-*-*	16	250	265	280	4000	500	112,7	54,4
VNK-2-18-3-3-*-*	18	250	265	280	3600	400	116	56
VNK-2-20-3-3-*-*	20	220	235	250	3200	400	119,3	57,7
VNK-2-23-3-3-*-*	23	220	235	250	3000	400	122,6	59,3
VNK-2-25-3-3-*-*	25	200	215	230	3000	400	127,6	61,8
VNK-2-28-3-3-*-*	28	180	190	200	2500	400	132,6	64,3
VNK-2-30-3-3-*-*	30	160	170	180	2500	400	135,9	66

VNK2--2-**-***

Screws tightening torque at 70 ... 75 Nm



OUTLET INLET

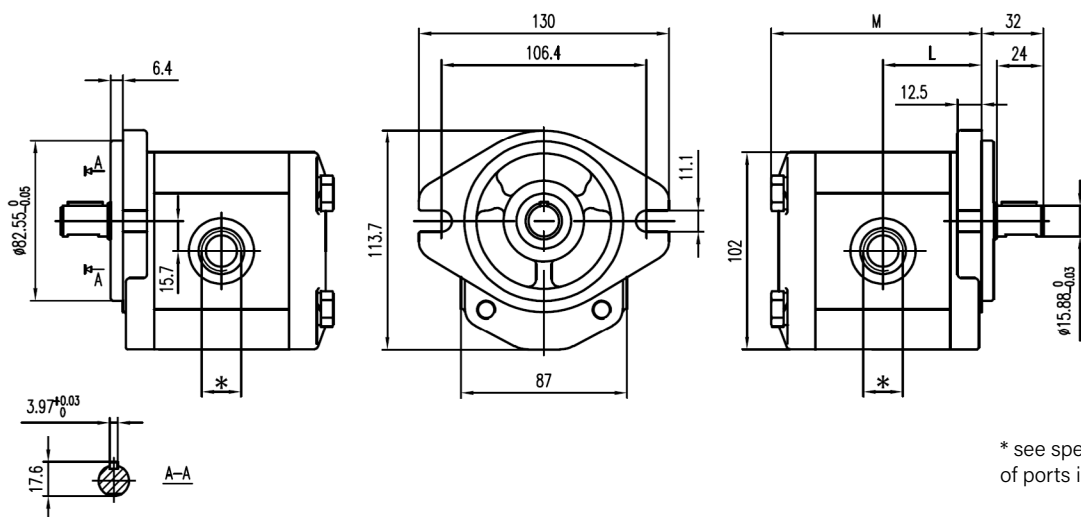

Type	Displacement cm ³ /rev	Max. Pressure			Max. Speed r/min	Min. Speed r/min	Dimensions	
		P1	P2	P3			M mm	L mm
VNK-2-4-**-2-**-*	4	270	285	300	4000	600	92,7	44,4
VNK-2-6-**-2-**-*	6	270	285	300	4000	600	96	46
VNK-2-8-**-2-**-*	8	270	285	300	3500	500	99,3	47,7
VNK-2-10-**-2-**-*	10	270	285	300	3000	500	102,6	49,3
VNK-2-12-**-2-**-*	12	270	285	300	3000	500	105,9	51
VNK-2-14-**-2-**-*	14	250	265	280	4000	500	109,3	52,7
VNK-2-16-**-2-**-*	16	250	265	280	4000	500	112,7	54,4
VNK-2-18-**-2-**-*	18	250	265	280	3600	400	116	56
VNK-2-20-**-2-**-*	20	220	235	250	3200	400	119,3	57,7
VNK-2-23-**-2-**-*	23	220	235	250	3000	400	122,6	59,3
VNK-2-25-**-2-**-*	25	200	215	230	3000	400	127,6	61,8
VNK-2-28-**-2-**-*	28	180	190	200	2500	400	132,6	64,3
VNK-2-30-**-2-**-*	30	160	170	180	2500	400	135,9	66

* see specifications of ports in page 29.

VNKB2--6-**-***

M6 thread depth 13. To mount the pump, n.4 M10 screws, with a torque wrench setting fixed at 70 ... 75 Nm.
 Shaft M 12x 1.5 nut, with a torque wrench setting fixed at 50 Nm.



OUTLET

INLET

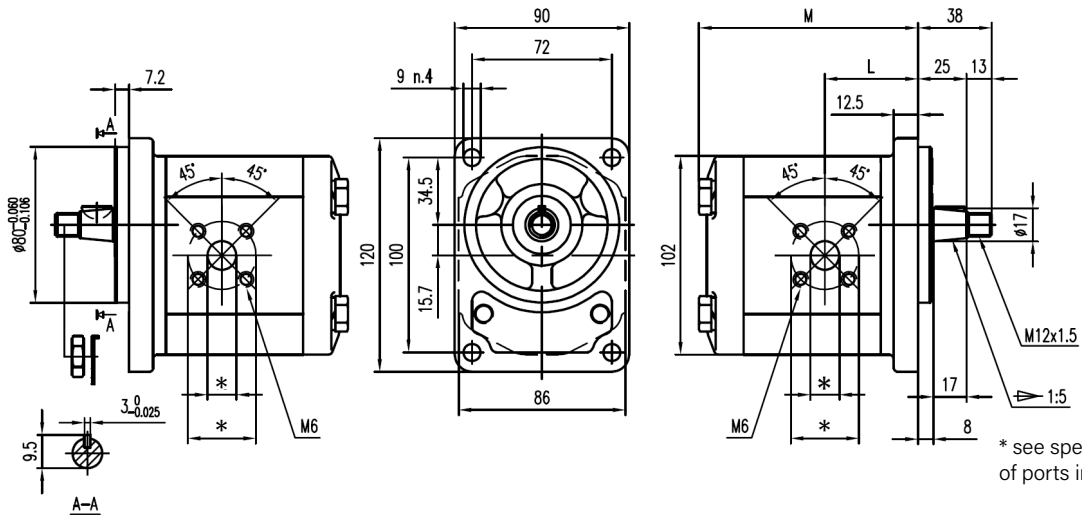

Type	Displacement cm ³ /rev	Max. Pressure			Max. Speed r/min	Min. Speed r/min	Dimensions	
		P1	P2	P3			M mm	L mm
VNK-2-4-*-6-**-*	4	270	285	300	4000	600	92,7	44,4
VNK-2-6-*-6-**-*	6	270	285	300	4000	600	96	46
VNK-2-8-*-6-**-*	8	270	285	300	3500	500	99,3	47,7
VNK-2-10-*-6-**-*	10	270	285	300	3000	500	102,6	49,3
VNK-2-12-*-6-**-*	12	270	285	300	3000	500	105,9	51
VNK-2-14-*-6-**-*	14	250	265	280	4000	500	109,3	52,7
VNK-2-16-*-6-**-*	16	250	265	280	4000	500	112,7	54,4
VNK-2-18-*-6-**-*	18	250	265	280	3600	400	116	56
VNK-2-20-*-6-**-*	20	220	235	250	3200	400	119,3	57,7
VNK-2-23-*-6-**-*	23	220	235	250	3000	400	122,6	59,3
VNK-2-25-*-6-**-*	25	200	215	230	3000	400	127,6	61,8
VNK-2-28-*-6-**-*	28	180	190	200	2500	400	132,6	64,3
VNK-2-30-*-6-**-*	30	160	170	180	2500	400	135,9	66

VNKB2--4-**-***

M6 thread depth 13. To mount the pump, n.2 M10 screws, with a torque wrench setting fixed at 45 ... 50 Nm.
 Shaft M 12x 1.5 nut, with a torque wrench setting fixed at 50 Nm.



OUTLET

INLET

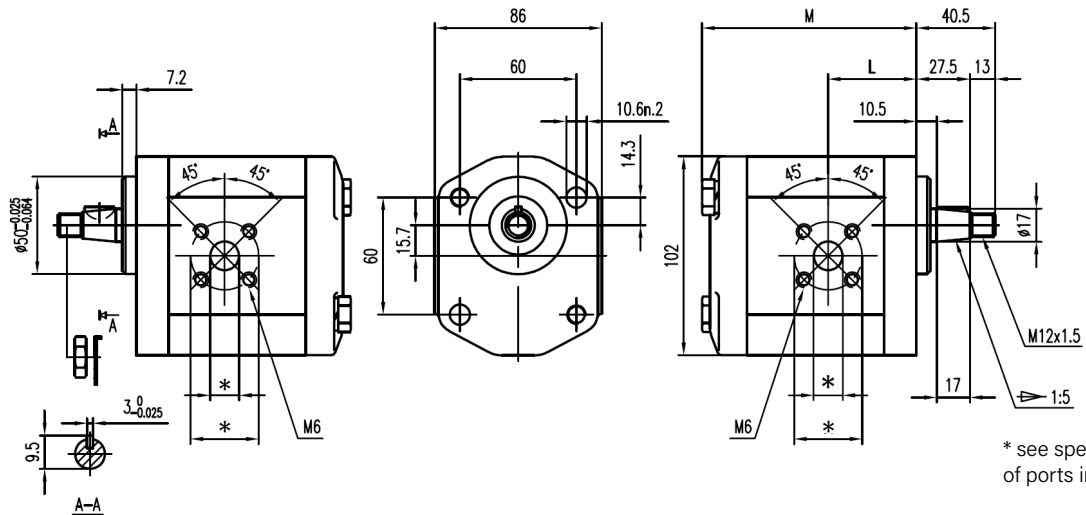

* see specifications of ports in page 29.

Type	Displacement cm ³ /rev	Max. Pressure			Max. Speed r/min	Min. Speed r/min	Dimensions	
		P1	P2	P3			M mm	L mm
VNK-2-4-**-4-**-*	4	270	285	300	4000	600	90,2	37,4
VNK-2-6-**-4-**-*	6	270	285	300	4000	600	93,5	38,6
VNK-2-8-**-4-**-*	8	270	285	300	3500	500	96,8	40,7
VNK-2-10-**-4-**-*	10	270	285	300	3000	500	100,1	41,2
VNK-2-12-**-4-**-*	12	270	285	300	3000	500	103,4	45
VNK-2-14-**-4-**-*	14	250	265	280	4000	500	106,8	45
VNK-2-16-**-4-**-*	16	250	265	280	4000	500	110,2	45
VNK-2-18-**-4-**-*	18	250	265	280	3600	400	113,5	45
VNK-2-20-**-4-**-*	20	220	235	250	3200	400	116,8	45
VNK-2-23-**-4-**-*	23	220	235	250	3000	400	120,1	52,6
VNK-2-25-**-4-**-*	25	200	215	230	3000	400	125,1	59,3
VNK-2-28-**-4-**-*	28	180	190	200	2500	400	130,1	51,8
VNK-2-30-**-4-**-*	30	160	170	180	2500	400	133,4	63,5

VNKB2--*-9-**-****

M6 thread depth 13. To mount the pump, n.2 M10 screws, with a torque wrench setting fixed at 45 ...50 Nm.
 Shaft M 12x 1.5 nut, with a torque wrench setting fixed at 50 Nm.



OUTLET

INLET

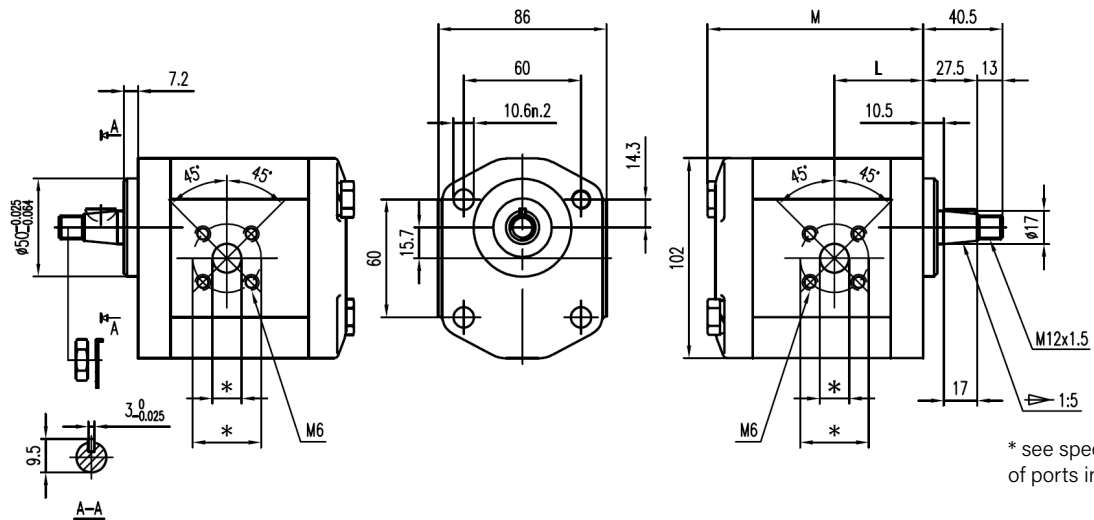

* see specifications of ports in page 29.

Type	Displacement cm ³ /rev	Max. Pressure			Max. Speed r/min	Min. Speed r/min	Dimensions	
		P1	P2	P3			M mm	L mm
VNK-2-4-*-9-*-C	4	4	270	285	300	4000	90,2	37,4
VNK-2-6-*-9-*-C	6	6	270	285	300	4000	93,5	38,6
VNK-2-8-*-9-*-C	8	8	270	285	300	3500	96,8	40,7
VNK-2-10-*-9-*-C	10	10	270	285	300	3000	100,1	41,2
VNK-2-12-*-9-*-C	12	12	270	285	300	3000	103,4	45
VNK-2-14-*-9-*-C	14	14	250	265	280	4000	106,8	45
VNK-2-16-*-9-*-C	16	16	250	265	280	4000	110,2	45
VNK-2-18-*-9-*-C	18	18	250	265	280	3600	113,5	45
VNK-2-20-*-9-*-C	20	20	220	235	250	3200	116,8	45
VNK-2-23-*-9-*-C	23	23	220	235	250	3000	120,1	52,6
VNK-2-25-*-9-*-C	25	25	200	215	230	3000	125,1	59,3
VNK-2-28-*-9-*-C	28	28	180	190	200	2500	130,1	51,8
VNK-2-30-*-9-*-C	30	30	160	170	180	2500	133,4	63,5

VNKB2--*-10-**-****

M6 thread depth 13. To mount the pump, n.2 M10 screws, with a torque wrench setting fixed at 45 ...50 Nm.
 Shaft M 12x 1.5 nut, with a torque wrench setting fixed at 70 Nm.

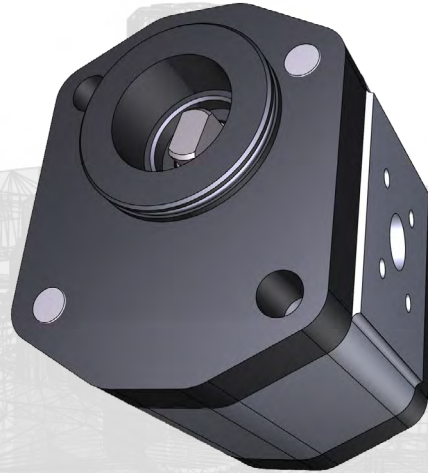

OUTLET

INLET

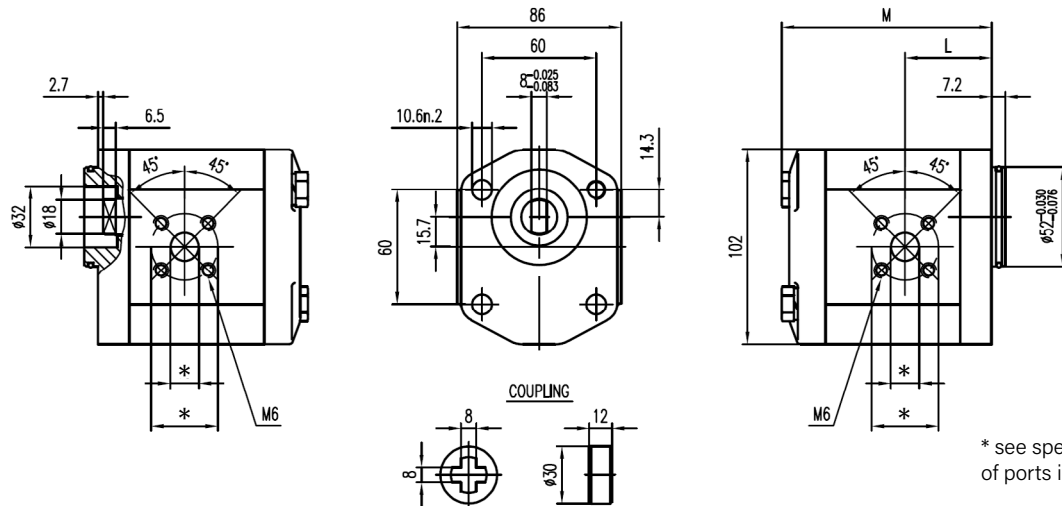

Type	Displacement cm ³ /rev	Max. Pressure			Max. Speed r/min	Min. Speed r/min	Dimensions	
		P1	P2	P3			M mm	L mm
VNK-2-4-*-10-*-C	4	4	270	285	300	4000	90,2	37,4
VNK-2-6-*-10-*-C	6	6	270	285	300	4000	93,5	38,6
VNK-2-8-*-10-*-C	8	8	270	285	300	3500	96,8	40,7
VNK-2-10-*-10-*-C	10	10	270	285	300	3000	100,1	41,2
VNK-2-12-*-10-*-C	12	12	270	285	300	3000	103,4	45
VNK-2-14-*-10-*-C	14	14	250	265	280	4000	106,8	45
VNK-2-16-*-10-*-C	16	16	250	265	280	4000	110,2	45
VNK-2-18-*-10-*-C	18	18	250	265	280	3600	113,5	45
VNK-2-20-*-10-*-C	20	20	220	235	250	3200	116,8	45
VNK-2-23-*-10-*-C	23	23	220	235	250	3000	120,1	52,6
VNK-2-25-*-10-*-C	25	25	200	215	230	3000	125,1	59,3
VNK-2-28-*-10-*-C	28	28	180	190	200	2500	130,1	51,8
VNK-2-30-*-10-*-C	30	30	160	170	180	2500	133,4	63,5

VNKB2--8-**-***

8 thread depth 16. To mount the pump, n.4 M10 screws, with a torque wrench setting fixed at 70 ... 75 Nm.

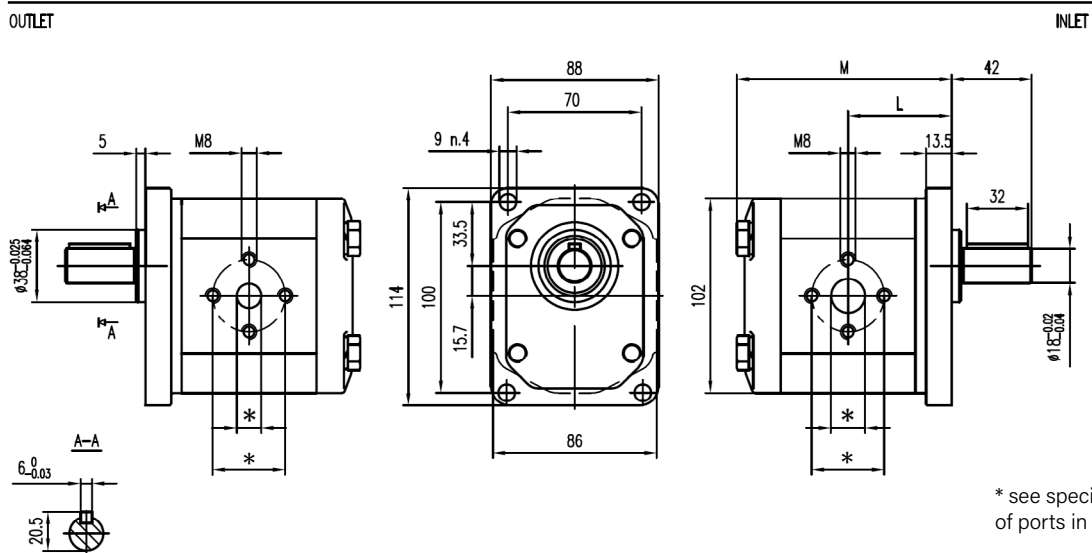

Type	Displacement cm ³ /rev	Max. Pressure			Max. Speed r/min	Min. Speed r/min	Dimensions	
		P1	P2	P3			M mm	L mm
VNK-2-4-**-8-**-*	4	270	285	300	4000	600	92,7	44,4
VNK-2-6-**-8-**-*	6	270	285	300	4000	600	96	46
VNK-2-8-**-8-**-*	8	270	285	300	3500	500	99,3	47,7
VNK-2-10-**-8-**-*	10	270	285	300	3000	500	102,6	49,3
VNK-2-12-**-8-**-*	12	270	285	300	3000	500	105,9	51
VNK-2-14-**-8-**-*	14	250	265	280	4000	500	109,3	52,7
VNK-2-16-**-8-**-*	16	250	265	280	4000	500	112,7	54,4
VNK-2-18-**-8-**-*	18	250	265	280	3600	400	116	56
VNK-2-20-**-8-**-*	20	220	235	250	3200	400	119,3	57,7
VNK-2-23-**-8-**-*	23	220	235	250	3000	400	122,6	59,3
VNK-2-25-**-8-**-*	25	200	215	230	3000	400	127,6	61,8
VNK-2-28-**-8-**-*	28	180	190	200	2500	400	132,6	64,3
VNK-2-30-**-8-**-*	30	160	170	180	2500	400	135,9	66

* see specifications of ports in page 29.

FRONT COVERS

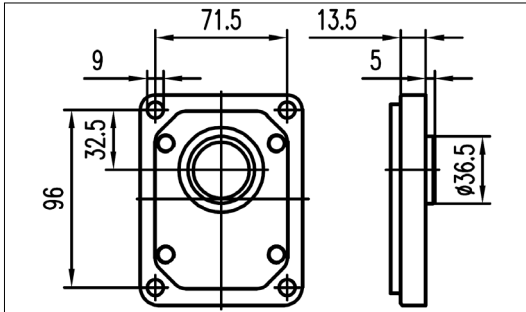

3

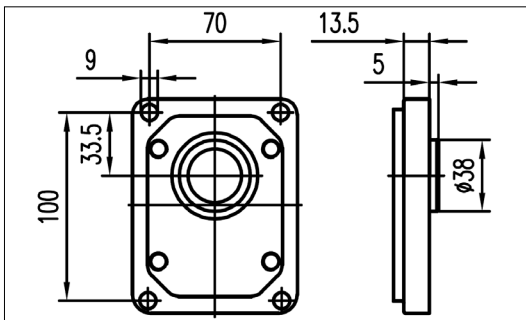

8

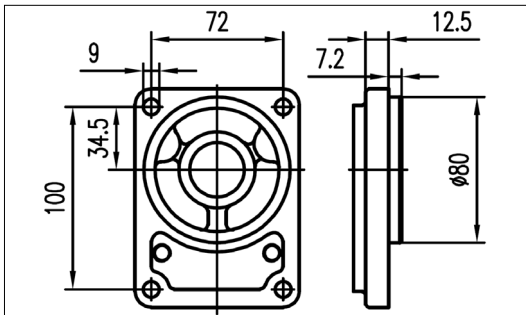

6

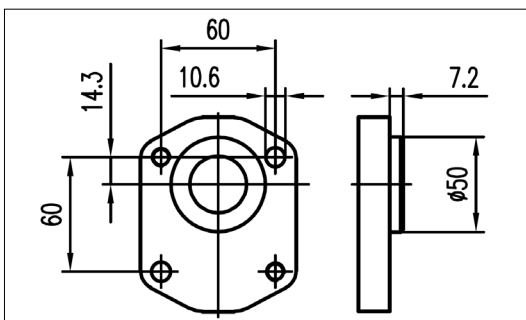

4

SHAFTS

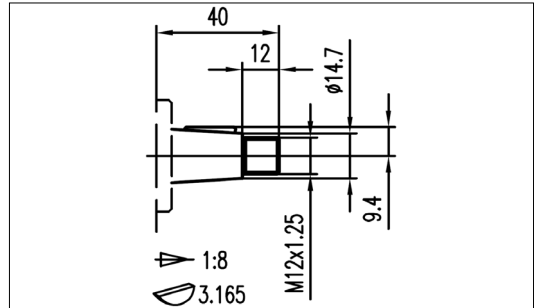

3

Max. Torque

200 Nm

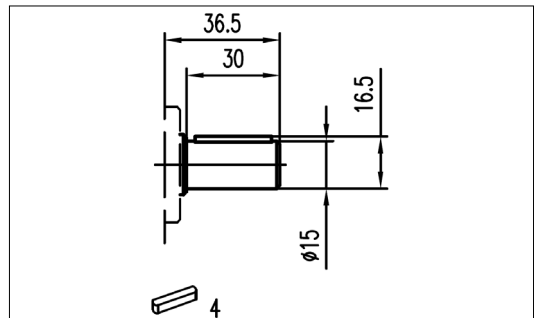

9

Max. Torque

135 Nm

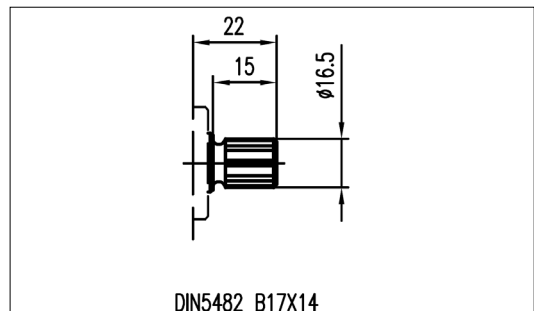

DIN5482 B17X14

12

Max. Torque

150 Nm

FRONT COVERS

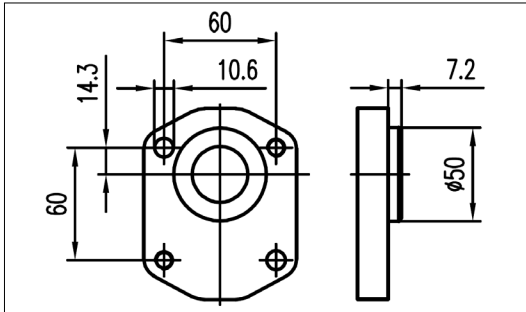

9

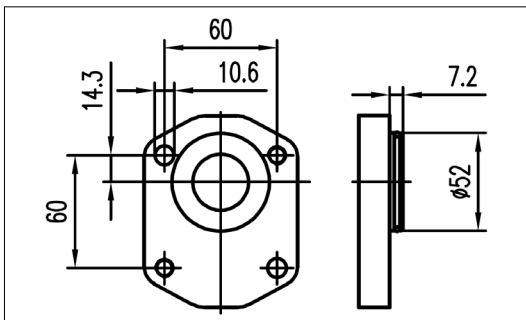

10

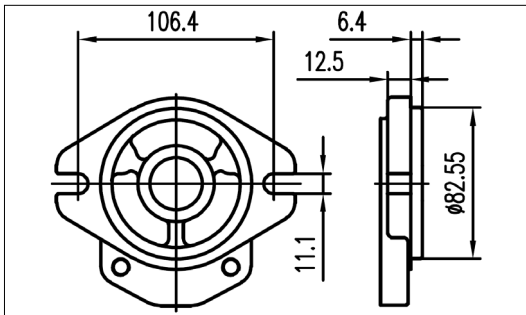

2

SHAFTS

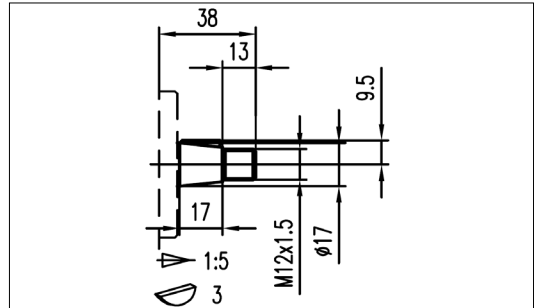

8

Max. Torque

180 Nm

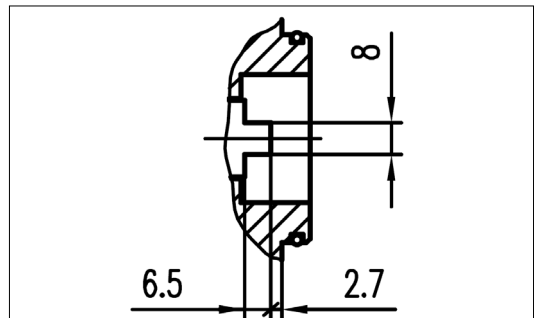

10

Max. Torque

100 Nm

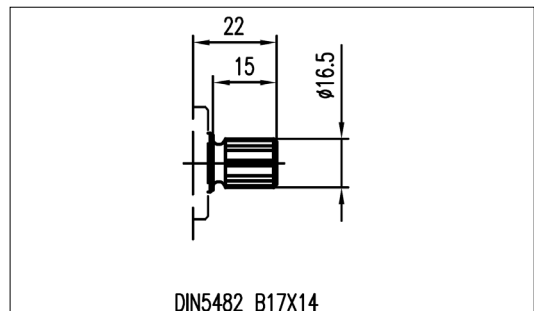

DIN5482 B17X14

11

Max. Torque

185 Nm

PORTS

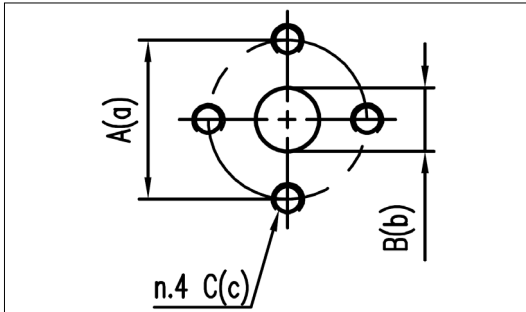

PORTS CODE	INLET			OUTLET		
	A	B	C	a	b	c
3030	30	13	M6	30	13	M6
4030	40	20	M8	30	13	M6
4040	40	21	M8	40	19	M8

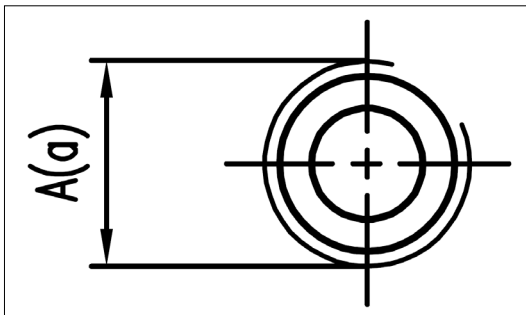

PORTS CODE	INLET	OUTLET
	A	a
1238	G1/2	G3/8
3412	G3/4	G1/2
1034	G1	G3/4

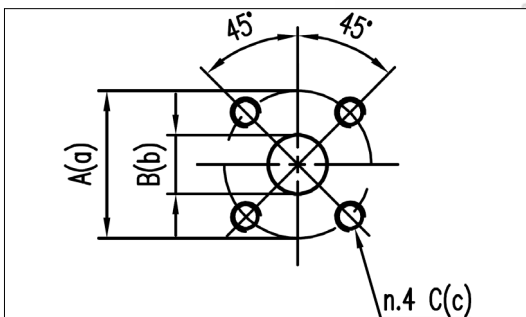

PORTS CODE	INLET			OUTLET		
	A	B	C	a	b	c
4035	40	20	M6	35	15	M6

VNK3 GEAR PUMP GROUP 3

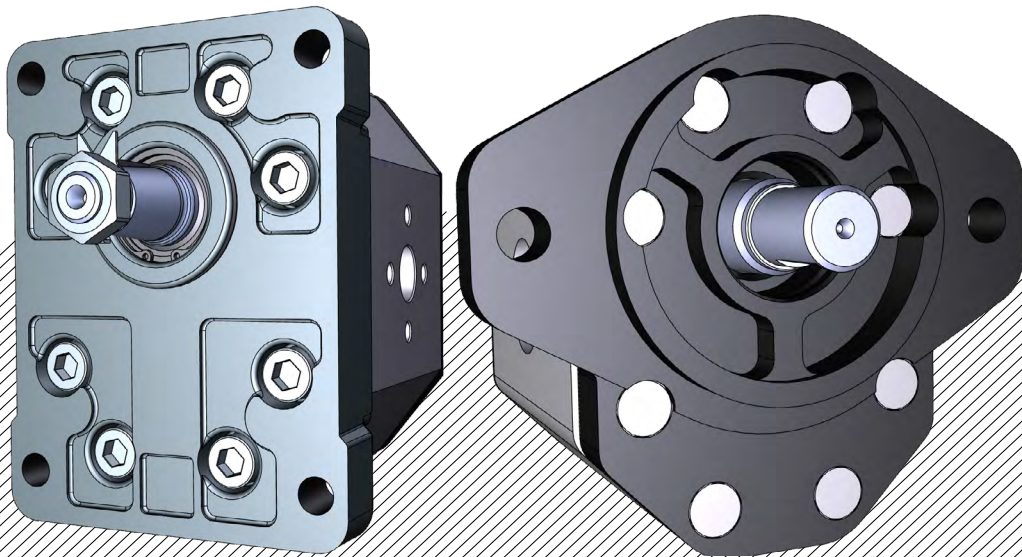

HOW TO ORDER

Single pump	Group	Size	Shaft *	Flange *	Inlet port *	Outlet port *	Rotation
VNKB	3	25	* see specifications of shafts, flanges and ports in pages 28, 29.				C
		28					A
		30					
		32					
		36					
		38					
		40					
		44					
		50					
		52					
		55					
		63					
		71					
		80					
90							
100							

C	Clockwise
A	Counter clockwise

VNK3--2-5--*

M10 thread depth 18, To mount the pump, n.8 M10 screws, with a torque wrench setting fixed at 47 ± 3 Nm.
 Shaft M 14x 1.5 nut, with a torque wrench setting fixed at 80 Nm.



OUTLET

INLET

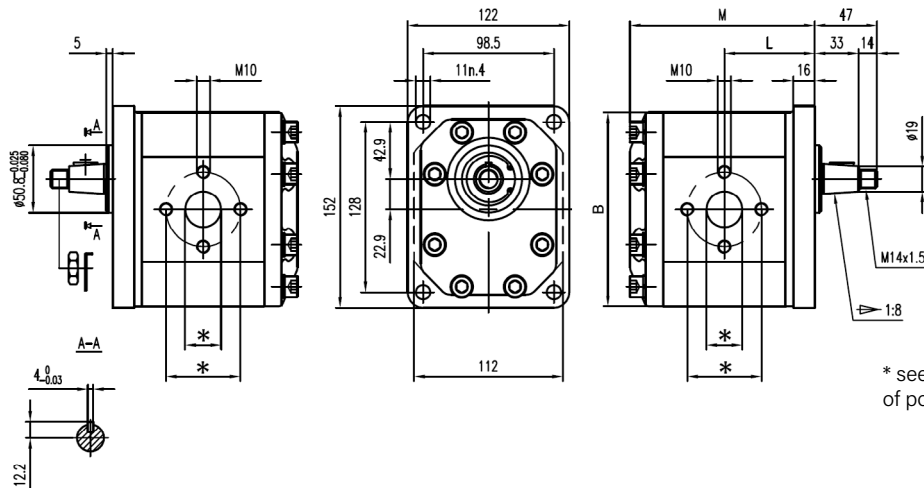

* see specifications of ports in page 29.

Type	Displacement cm ³ /rev	Max. Pressure			Max. Speed r/min	Min. Speed r/min	Dimensions		
		P1	P2	P3			M mm	L mm	B mm
VNKB3-25-2-5--*--*	25	260	290	300	3000	500	123	59,3	118
VNKB3-28-2-5--*--*	28	260	290	300	3000	500	126	60,8	118
VNKB3-30-2-5--*--*	30	250	280	300	3000	500	129	62	118
VNKB3-32-2-5--*--*	32	250	280	300	3000	500	131	63,3	118
VNKB3-36-2-5--*--*	36	250	280	300	2750	400	135	65,3	118
VNKB3-38-2-5--*--*	38	250	280	300	2750	400	137	66,3	118
VNKB3-40-2-5--*--*	40	250	280	300	2750	400	139	67,3	118
VNKB3-44-2-5--*--*	44	250	280	300	2750	400	144	69,5	118
VNKB3-50-2-5--*--*	50	220	240	260	3000	500	156	77	146
VNKB3-52-2-5--*--*	52	220	240	260	3000	500	158	78	146
VNKB3-55-2-5--*--*	55	220	240	260	2750	400	160	79	146
VNKB3-63-2-5--*--*	63	200	230	250	2750	400	168	83	146
VNKB3-71-2-5--*--*	71	180	200	220	2500	400	175	86	146
VNKB3-80-2-5--*--*	80	180	200	220	2500	400	189	96	146
VNKB3-90-2-5--*--*	90	180	200	220	2500	400	195	99	146
VNKB3-100-2-5--*--*	100	160	180	200	2500	400	201	102	146

VNK3-*-7-*

To mount the pump, n.8 M10 screws, with a torque wrench setting fixed at 47±3 Nm.



OUTLET

INLET

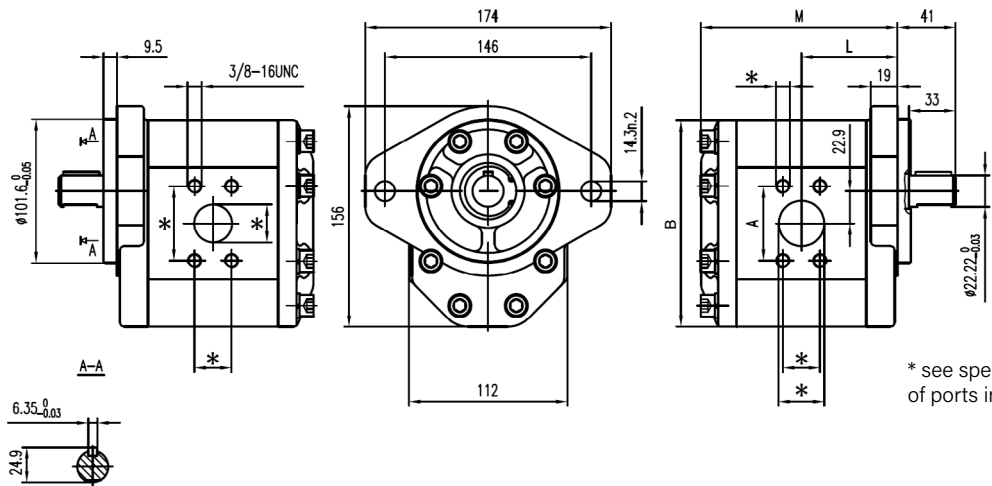

Type	Displacement cm ³ /rev	Max. Pressure			Max. Speed r/min	Min. Speed r/min	Dimensions		
		P1	P2	P3			M mm	L mm	B mm
VNKB3-25-*-7-***	25	260	290	300	3000	500	123	59,3	118
VNKB3-28-*-7-***	28	260	290	300	3000	500	126	60,8	118
VNKB3-30-*-7-***	30	250	280	300	3000	500	129	62	118
VNKB3-32-*-7-***	32	250	280	300	3000	500	131	63,3	118
VNKB3-36-*-7-***	36	250	280	300	2750	400	135	65,3	118
VNKB3-38-*-7-***	38	250	280	300	2750	400	137	66,3	118
VNKB3-40-*-7-***	40	250	280	300	2750	400	139	67,3	118
VNKB3-44-*-7-***	44	250	280	300	2750	400	144	69,5	118
VNKB3-50-*-7-***	50	220	240	260	3000	500	156	77	146
VNKB3-52-*-7-***	52	220	240	260	3000	500	158	78	146
VNKB3-55-*-7-***	55	220	240	260	2750	400	160	79	146
VNKB3-63-*-7-***	63	200	230	250	2750	400	168	83	146
VNKB3-71-*-7-***	71	180	200	220	2500	400	175	86	146
VNKB3-80-*-7-***	80	180	200	220	2500	400	189	96	146
VNKB3-90-*-7-***	90	180	200	220	2500	400	195	99	146
VNKB3-100-*-7-***	100	160	180	200	2500	400	201	102	146

FRONT COVERS

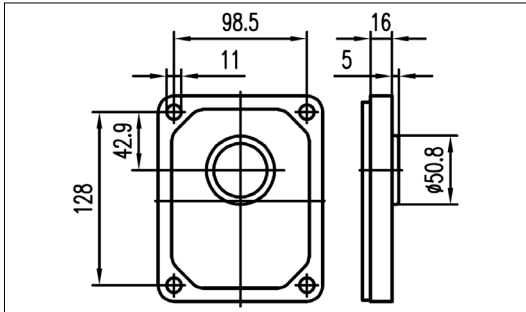

5

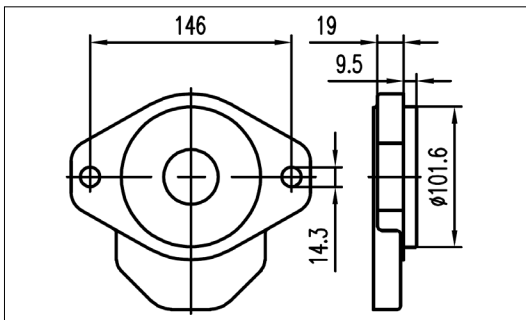

7

SHAFTS

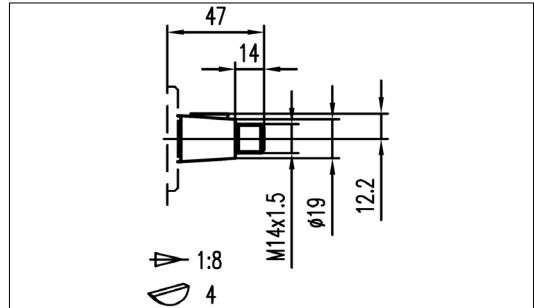

2

Max. Torque

300 Nm

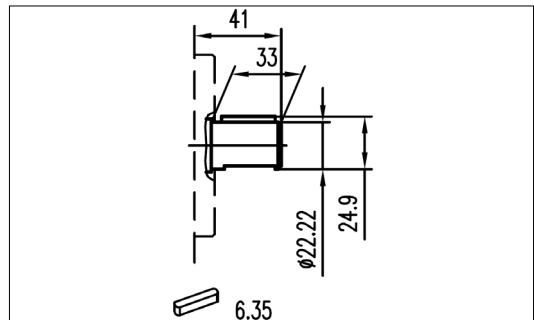

14

Max. Torque

400 Nm

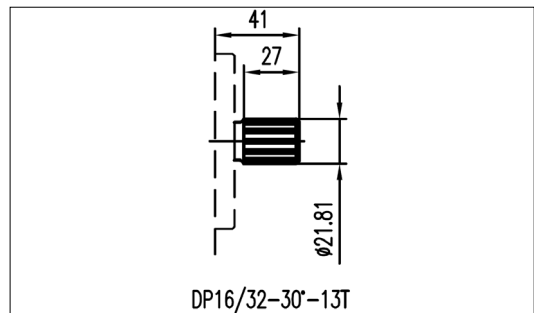

15

Max. Torque

500 Nm

PORTS

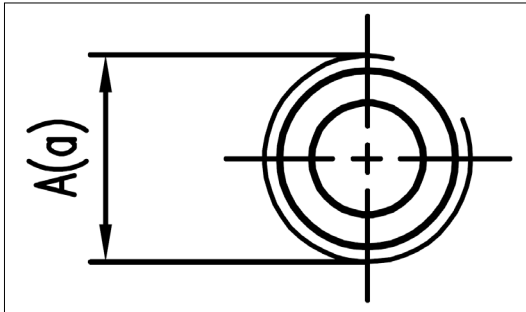

PORTS CODE	INLET		OUTLET	
	A	a		
10 34	G1	G3/4		
114 10	G1 1/4	G1		
112 114	G1 1/2	G1 1/4		

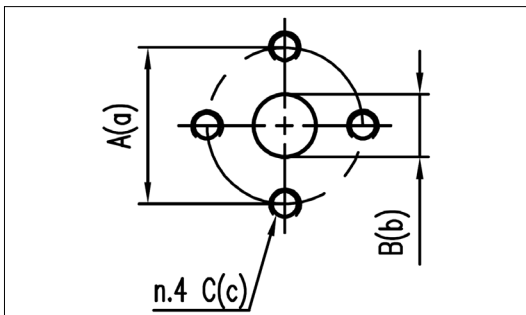

PORTS CODE	INLET			OUTLET		
	A	B	C	a	b	c
51 40	51	25	M10	40	18	M8
62 51	62	33	M10	51	27	M10
62 62	62	33	M10	62	33	M10

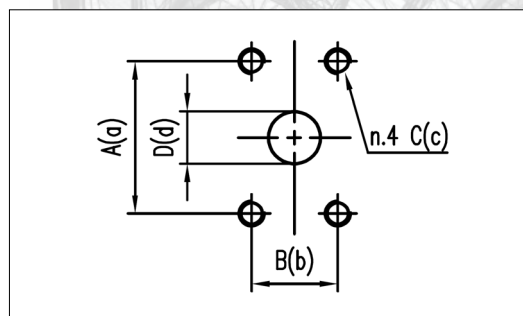

PORTS CODE	INLET				OUTLET			
	A	B	C	D	a	b	c	d
52 47	52.4	26.2	3/8-16UNC	27	47.6	22.2	3/8-16UNC	19
58 52	58.7	30.2	7/16-14UNC	33	52.4	26.2	3/8-16UNC	27

MULTIPLE PUMPS

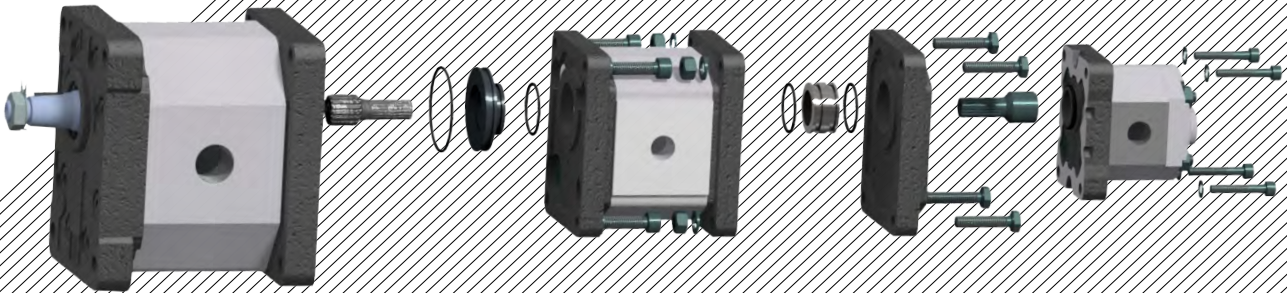

The VNKBM pumps can be easily transformed in multiple units. All drive shafts are pre-arranged and have a splined end according DIN 5480. The first unit must always be the same size or bigger than following units. The features and performances are the same of the corresponding single units: only in the case of simultaneous operating you have to verify that the inlet torque is lower than the max. transmissible by the drive shaft. Finally to assembly the multiple pump you need to order bolts of the right lenght.

Standard Version

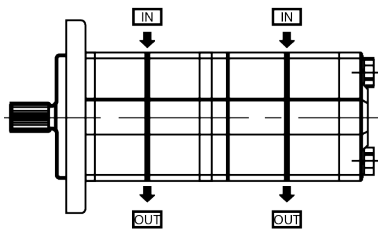

S

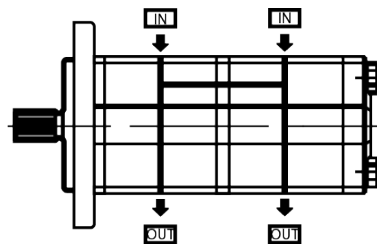

H

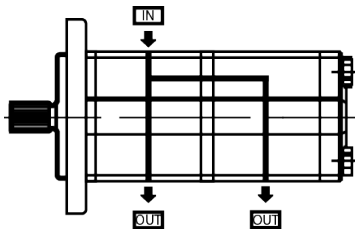

J

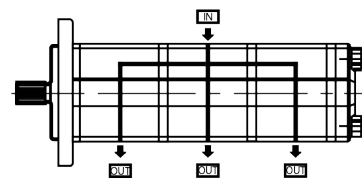

W

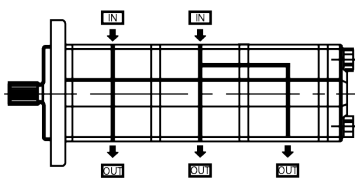

R

S- two inlet and two outlet (separated type)

H- two inlet and two outlet (common type)

J- one inlet and two outlet

W- one inlet and three outlet

R- two inlet and three outlet

VNKBMD - DRIVER PUMP

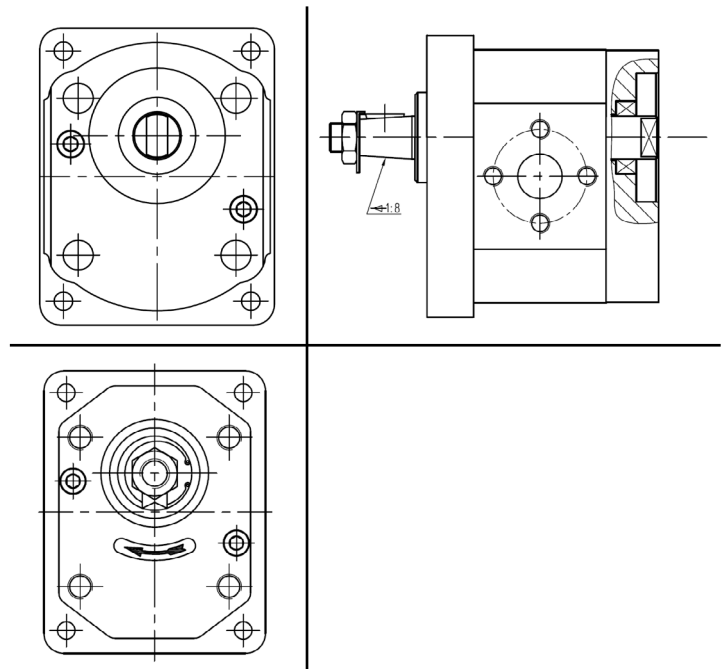

HOW TO ORDER

Multiple pump	Group	Size	Shaft *	Flange *	Inlet port *	Outlet port *	Rotation	Standard Version
---------------	-------	------	---------	----------	--------------	---------------	----------	------------------

VNKBMD	3		25					
	2		4	30				
	1	1.1	6	33				
		1.3	8	39				
		1.6	10	46				
		1.8	12	50				
		2.1	14	55				
		2.7	16	63				
		3.2	18	70				
		3.7	20	80				
		4.2	23	90				
		5	25					
		5.8	30					
		7						
	8							

* see specifications of shafts, flanges and ports in pages 42, 43, 44, 45, 46.

C	Clockwise	S
A	Counter clockwise	H
		J
		W
		R

VNKBMD GROUP 1



VNK1/1-S

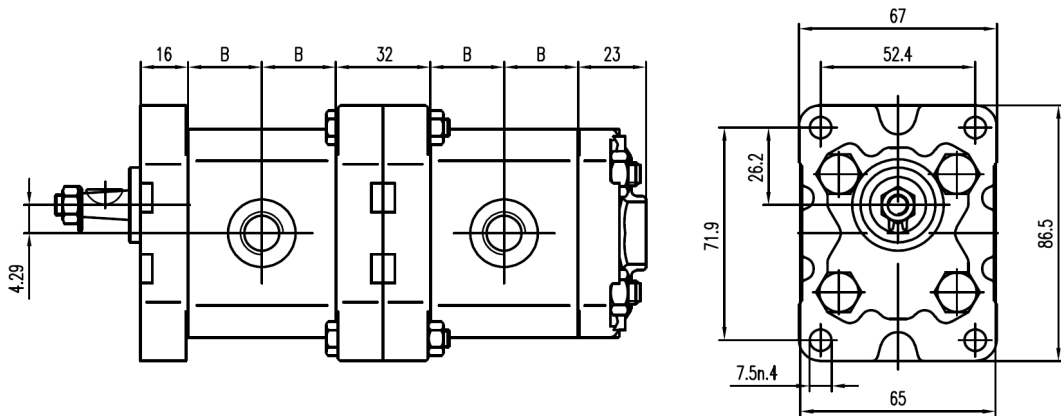
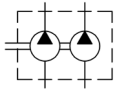

Type	Displacement cm ³ /rev	Max. Pressure			Max. Speed r/min	Min. Speed r/min	Dimensions
		P1	P2	P3			B mm
VNKBMD-1-1.1-1-1-*.**	1.1	250	270	290	6000	1000	18,5
VNKBMD-1-1.3-1-1-*.**	1.3	250	270	290	6000	1000	19
VNKBMD-1-1.6-1-1-*.**	1.6	250	270	290	6000	1000	19,5
VNKBMD-1-1.8-1-1-*.**	1.8	250	270	290	6000	1000	20
VNKBMD-1-2.1-1-1-*.**	2.1	250	270	290	6000	1000	21
VNKBMD-1-2.7-1-1-*.**	2.7	250	270	290	6000	1000	22
VNKBMD-1-3.2-1-1-*.**	3.2	250	270	290	6000	800	23
VNKBMD-1-3.7-1-1-*.**	3.7	250	270	290	5000	800	24
VNKBMD-1-4.2-1-1-*.**	4.2	250	270	290	4500	800	25
VNKBMD-1-4.8-1-1-*.**	4.8	230	250	270	4000	800	26
VNKBMD-1-5.8-1-1-*.**	5.8	230	250	270	3500	600	28
VNKBMD-1-7-1-*.**	7	210	230	250	3000	600	30
VNKBMD-1-8-1-1-*.**	8	180	200	230	2500	600	32

VNKBMD GROUP 2



VNK2/2/2-S

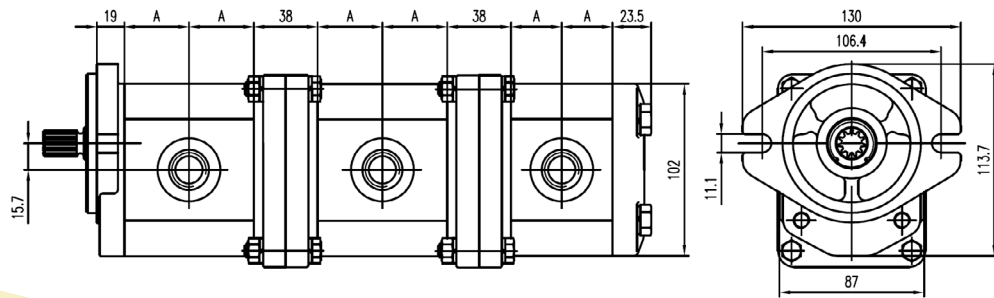

VNK2/1-S

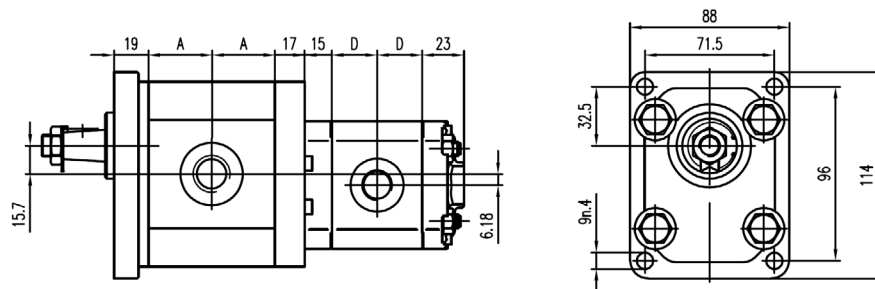

Type	Displacement	Max. Pressure			Max. Speed	Min. Speed	Dimensions
		P1	P2	P3			A
	cm ³ /rev				r/min	r/min	mm
VNKBMD2-4-*.~*.~*.~*	4	270	285	300	4000	600	25,3
VNKBMD2-6-*.~*.~*.~*	6	270	285	300	4000	600	27
VNKBMD2-8-*.~*.~*.~*	8	270	285	300	3500	500	28,6
VNKBMD2-10-*.~*.~*.~*	10	270	285	300	3000	500	30,3
VNKBMD2-12-*.~*.~*.~*	12	270	285	300	3000	500	32
VNKBMD2-14-*.~*.~*.~*	14	250	265	280	4000	500	33,6
VNKBMD2-16-*.~*.~*.~*	16	250	265	280	4000	500	35,3
VNKBMD2-18-*.~*.~*.~*	18	250	265	280	3600	400	37
VNKBMD2-20-*.~*.~*.~*	20	220	235	250	3200	400	38,6
VNKBMD2-2*.~*.~*.~*3-*.~*.~*	23	220	235	250	3000	400	40,3
VNKBMD2-25-*.~*.~*.~*	25	200	215	230	3000	400	42,8
VNKBMD2-28-*.~*.~*.~*	28	180	190	200	2500	400	45,3
VNKBMD2-30-*.~*.~*.~*	30	160	170	180	2500	400	47

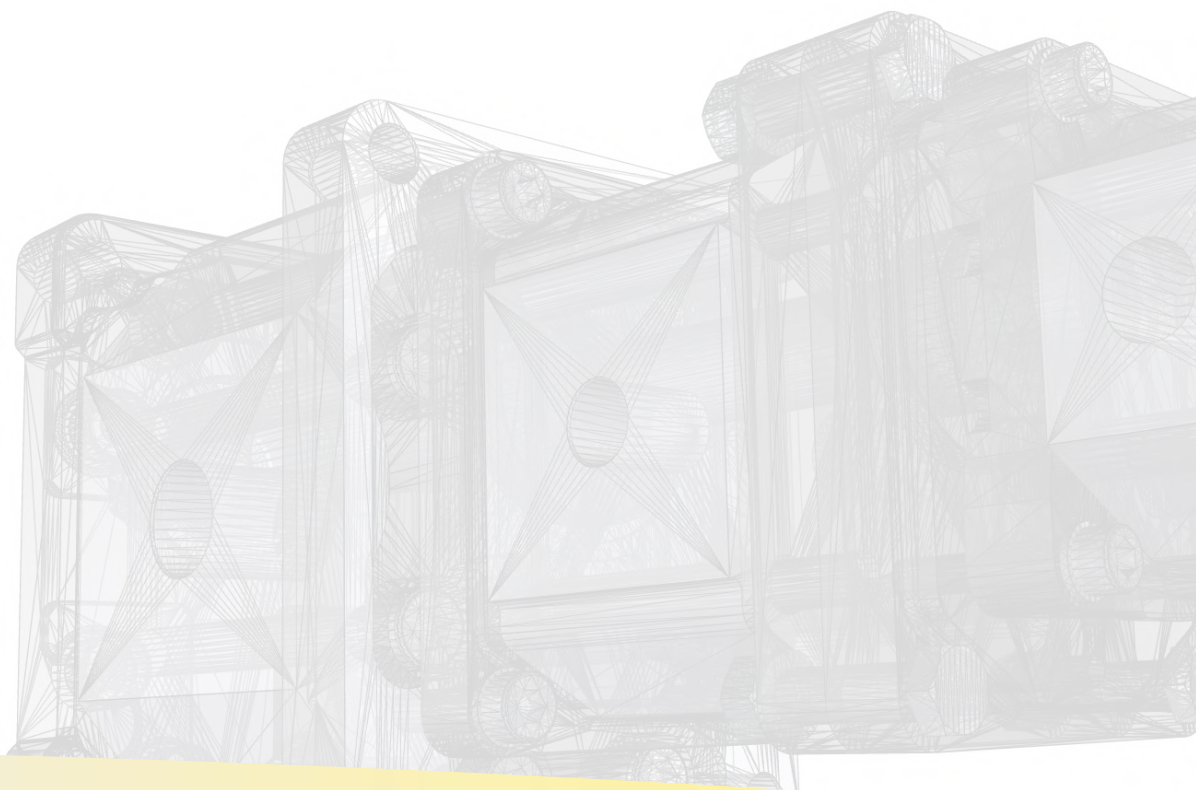

VNKBMD GROUP 3



VNK3/3-S

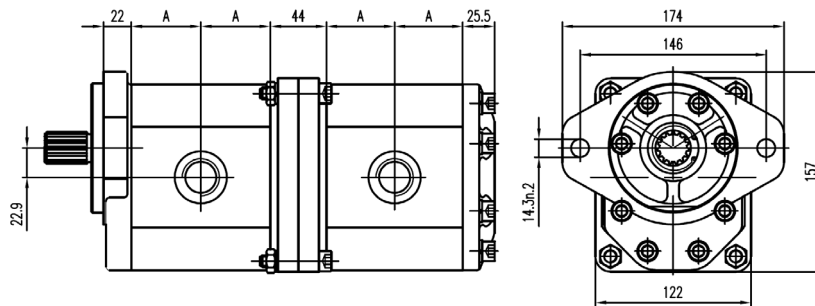
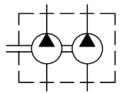

VNK3/2-S

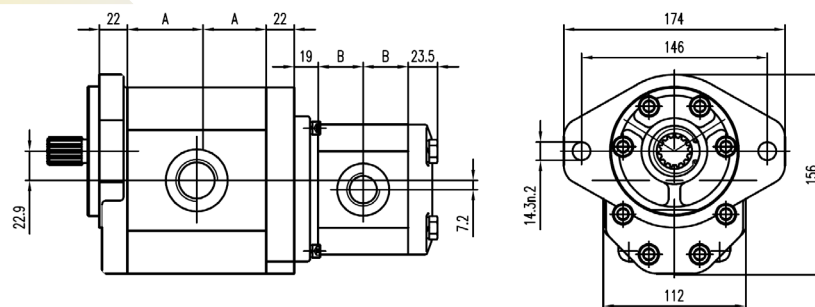
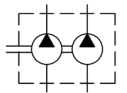

VNK3/1-S

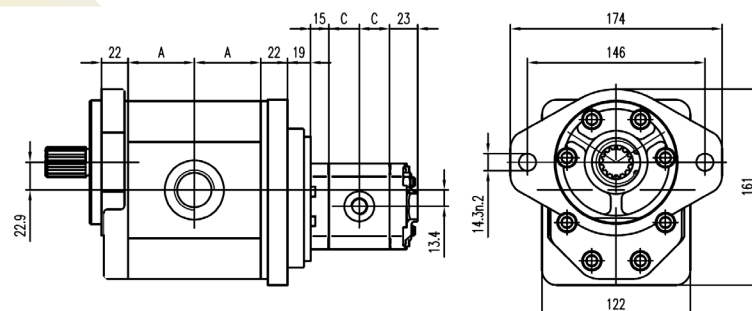
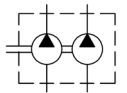

Type	Displacement cm ³ /rev	Max. Pressure			Max. Speed r/min	Min. Speed r/min	Dimensions
		P1	P2	P3			A mm
VNKBMD3-25-*.***	25	260	290	300	3000	500	43
VNKBMD3-30-*.***	30	250	280	300	3000	500	46
VNKBMD3-33-*.***	33	250	280	300	3000	500	49,5
VNKBMD3-39-*.***	39	250	280	300	2750	400	52,5
VNKBMD3-46-*.***	46	250	280	300	2750	400	54,5
VNKBMD3-50-*.***	50	220	240	260	3000	500	55,5
VNKBMD3-55-*.***	55	220	240	260	2750	400	56,5
VNKBMD3-63-*.***	63	200	230	250	2750	400	60,7
VNKBMD3-71-*.***	71	180	200	220	2500	400	64
VNKBMD3-80-*.***	80	180	200	220	2500	400	71
VNKBMD3-90-*.***	90	180	200	220	2500	400	80
VNKBMD2-28-*.***	28	180	190	200	2500	400	45,3
VNKBMD2-30-*.***	30	160	170	180	2500	400	47



VNKBMI - INTERMEDIATE PUMP

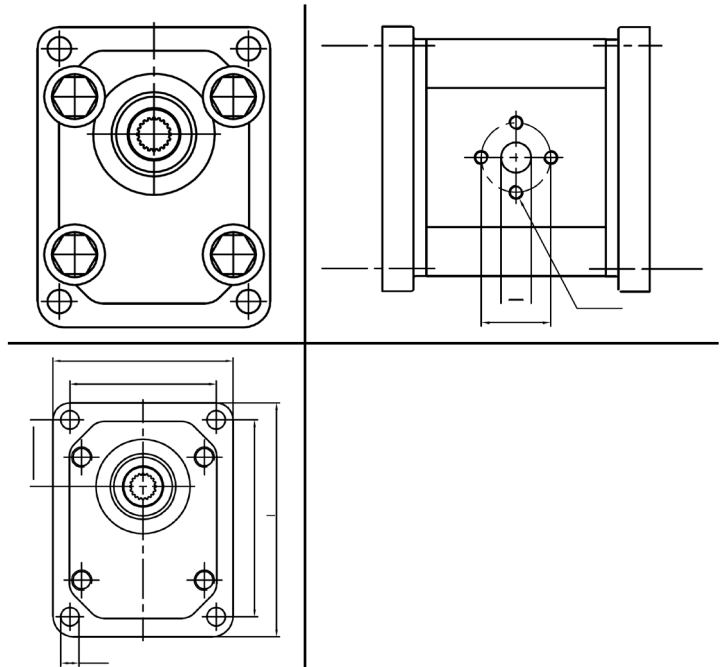

HOW TO ORDER

Multiple pump	Group	Size	Inlet port *	Outlet port *	Rotation	Standard Version
---------------	-------	------	--------------	---------------	----------	------------------

VNKBMI	3			25
	2		4	30
	1	1.1	6	33
		1.3	8	39
		1.6	10	46
		1.8	12	50
		2.1	14	55
		2.7	16	63
		3.2	18	70
		3.7	20	80
		4.2	23	90
		5	25	
		5.8	30	
		7		
	8			

C	Clockwise	S
A	Counter clockwise	H
		J
		W
		R

* see specifications of ports in pages 42, 43, 44, 45, 46.

Type	Displacement	Max. Pressure			Max. Speed	Min. Speed	Dimensions
							B
	cm ³ /rev	P1	P2	P3	r/min	r/min	mm
VNKBMI-1-11-1-1-*.**	1.1	250	270	290	6000	1000	18,5
VNKBMI-1-13-1-1-*.**	1.3	250	270	290	6000	1000	19
VNKBMI-1-16-1-1-*.**	1.6	250	270	290	6000	1000	19,5
VNKBMI-1-18-1-1-*.**	1.8	250	270	290	6000	1000	20
VNKBMI-1-21-1-1-*.**	2.1	250	270	290	6000	1000	21
VNKBMI-1-27-1-1-*.**	2.7	250	270	290	6000	1000	22
VNKBMI-1-32-1-1-*.**	3.2	250	270	290	6000	800	23
VNKBMI-1-37-1-1-*.**	3.7	250	270	290	5000	800	24
VNKBMI-1-42-1-1-*.**	4.2	250	270	290	4500	800	25
VNKBMI-1-48-1-1-*.**	4.8	230	250	270	4000	800	26
VNKBMI-1-58-1-1-*.**	5.8	230	250	270	3500	600	28
VNKBMI-1-7-1-*.**	7	210	230	250	3000	600	30
VNKBMI-1-8-1-1-*.**	8	180	200	230	2500	600	32

Type	Displacement	Max. Pressure			Max. Speed	Min. Speed	Dimensions
							A
	cm ³ /rev	P1	P2	P3	r/min	r/min	mm
VNKBMI2-4-*.**.*	4	270	285	300	4000	600	25,3
VNKBMI2-6-*.**.*	6	270	285	300	4000	600	27
VNKBMI2-8-*.**.*	8	270	285	300	3500	500	28,6
VNKBMI2-10-*.**.*	10	270	285	300	3000	500	30,3
VNKBMI2-12-*.**.*	12	270	285	300	3000	500	32
VNKBMI2-14-*.**.*	14	250	265	280	4000	500	33,6
VNKBMI2-16-*.**.*	16	250	265	280	4000	500	35,3
VNKBMI2-18-*.**.*	18	250	265	280	3600	400	37
VNKBMI2-20-*.**.*	20	220	235	250	3200	400	38,6
VNKBMI2-2*-3-*.**.*	23	220	235	250	3000	400	40,3
VNKBMI2-25-*.**.*	25	200	215	230	3000	400	42,8
VNKBMI2-28-*.**.*	28	180	190	200	2500	400	45,3
VNKBMI2-30-*.**.*	30	160	170	180	2500	400	47

Type	Displacement	Max. Pressure			Max. Speed	Min. Speed	Dimensions
							A
	cm ³ /rev	P1	P2	P3	r/min	r/min	mm
VNKBMI3-25-*.**.*	25	260	290	300	3000	500	43
VNKBMI3-30-*.**.*	30	250	280	300	3000	500	46
VNKBMI3-33-*.**.*	33	250	280	300	3000	500	49,5
VNKBMI3-39-*.**.*	39	250	280	300	2750	400	52,5
VNKBMI3-46-*.**.*	46	250	280	300	2750	400	54,5
VNKBMI3-50-*.**.*	50	220	240	260	3000	500	55,5
VNKBMI3-55-*.**.*	55	220	240	260	2750	400	56,5
VNKBMI3-63-*.**.*	63	200	230	250	2750	400	60,7
VNKBMI3-71-*.**.*	71	180	200	220	2500	400	64
VNKBMI3-80-*.**.*	80	180	200	220	2500	400	71
VNKBMI3-90-*.**.*	90	180	200	220	2500	400	80
VNKBMD2-28-*.**.*	28	180	190	200	2500	400	45,3
VNKBMD2-30-*.**.*	30	160	170	180	2500	400	47

VNKBMF - FINAL PUMP

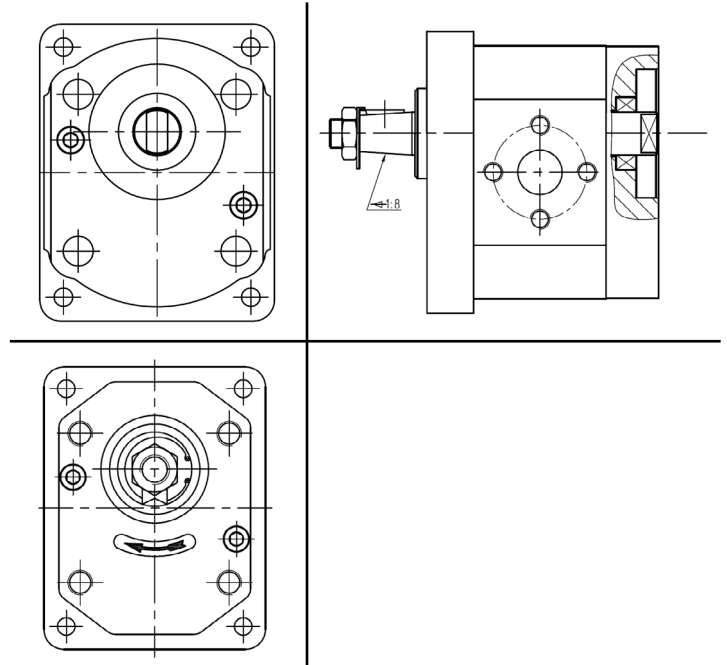

HOW TO ORDER

Multiple pump	Group	Size	Inlet port *	Outlet port *	Rotation	Standard Version
---------------	-------	------	--------------	---------------	----------	------------------

VNKBMF	3			25
	2		4	30
	1	1.1	6	33
		1.3	8	39
		1.6	10	46
		1.8	12	50
		2.1	14	55
		2.7	16	63
		3.2	18	70
		3.7	20	80
		4.2	23	90
		5	25	
		5.8	30	
		7		
	8			

C	Clockwise	S
A	Counter clockwise	H
		J
		W
		R

* see specifications of ports in pages 42, 43, 44, 45, 46.

Type	Displacement	Max. Pressure			Max. Speed	Min. Speed	Dimensions
							B
	cm³/rev	P1	P2	P3	r/min	r/min	mm
VNKBMF-1-1.1-1-1-*.***	1.1	250	270	290	6000	1000	18,5
VNKBMF-1-1.3-1-1-*.***	1.3	250	270	290	6000	1000	19
VNKBMF-1-1.6-1-1-*.***	1.6	250	270	290	6000	1000	19,5
VNKBMF-1-1.8-1-1-*.***	1.8	250	270	290	6000	1000	20
VNKBMF-1-2.1-1-1-*.***	2.1	250	270	290	6000	1000	21
VNKBMF-1-2.7-1-1-*.***	2.7	250	270	290	6000	1000	22
VNKBMF-1-3.2-1-1-*.***	3.2	250	270	290	6000	800	23
VNKBMF-1-3.7-1-1-*.***	3.7	250	270	290	5000	800	24
VNKBMF-1-4.2-1-1-*.***	4.2	250	270	290	4500	800	25
VNKBMF-1-4.8-1-1-*.***	4.8	230	250	270	4000	800	26
VNKBMF-1-5.8-1-1-*.***	5.8	230	250	270	3500	600	28
VNKBMF-1-7-1-*.***	7	210	230	250	3000	600	30
VNKBMF-1-8-1-1-*.***	8	180	200	230	2500	600	32

Type	Displacement	Max. Pressure			Max. Speed	Min. Speed	Dimensions
							A
	cm³/rev	P1	P2	P3	r/min	r/min	mm
VNKBMF2-4-*.***	4	270	285	300	4000	600	25,3
VNKBMF2-6-*.***	6	270	285	300	4000	600	27
VNKBMF2-8-*.***	8	270	285	300	3500	500	28,6
VNKBMF2-10-*.***	10	270	285	300	3000	500	30,3
VNKBMF2-12-*.***	12	270	285	300	3000	500	32
VNKBMF2-14-*.***	14	250	265	280	4000	500	33,6
VNKBMF2-16-*.***	16	250	265	280	4000	500	35,3
VNKBMF2-18-*.***	18	250	265	280	3600	400	37
VNKBMF2-20-*.***	20	220	235	250	3200	400	38,6
VNKBMF2-2*-3-*.***	23	220	235	250	3000	400	40,3
VNKBMF2-25-*.***	25	200	215	230	3000	400	42,8
VNKBMF2-28-*.***	28	180	190	200	2500	400	45,3
VNKBMF2-30-*.***	30	160	170	180	2500	400	47

Type	Displacement	Max. Pressure			Max. Speed	Min. Speed	Dimensions
							A
	cm³/rev	P1	P2	P3	r/min	r/min	mm
VNKBMF3-25-*.***	25	260	290	300	3000	500	43
VNKBMF3-30-*.***	30	250	280	300	3000	500	46
VNKBMF3-33-*.***	33	250	280	300	3000	500	49,5
VNKBMF3-39-*.***	39	250	280	300	2750	400	52,5
VNKBMF3-46-*.***	46	250	280	300	2750	400	54,5
VNKBMF3-50-*.***	50	220	240	260	3000	500	55,5
VNKBMF3-55-*.***	55	220	240	260	2750	400	56,5
VNKBMF3-63-*.***	63	200	230	250	2750	400	60,7
VNKBMF3-71-*.***	71	180	200	220	2500	400	64
VNKBMF3-80-*.***	80	180	200	220	2500	400	71
VNKBMF3-90-*.***	90	180	200	220	2500	400	80
VNKBMF2-28-*.***	28	180	190	200	2500	400	45,3
VNKBMF2-30-*.***	30	160	170	180	2500	400	47

KIT UNION

VNKBMK11	MULTIPLE PUMP KIT 1+1
VNKBMK21	MULTIPLE PUMP KIT 2+1
VNKBMK22	MULTIPLE PUMP KIT 2+2
VNKBMK31	MULTIPLE PUMP KIT 3+1
VNKBMK32	MULTIPLE PUMP KIT 3+2
VNKBMK33	MULTIPLE PUMP KIT 3+3

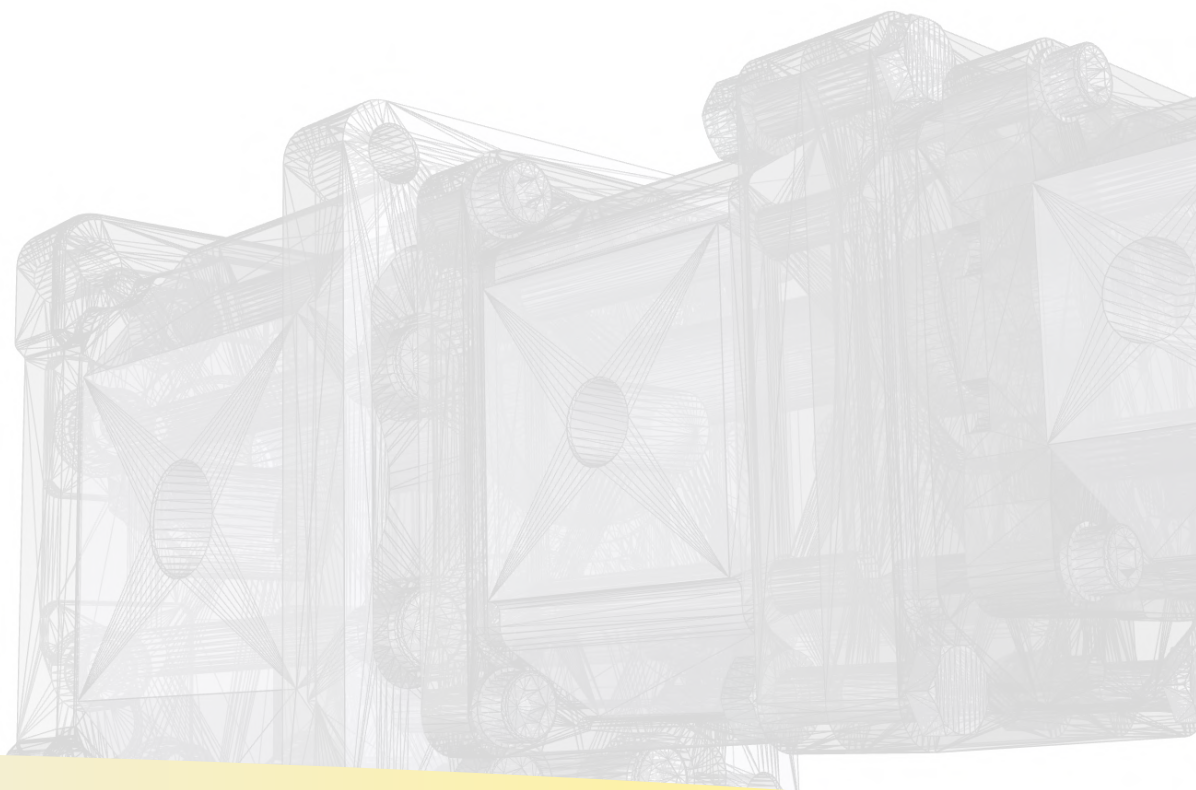

FRONT COVERS

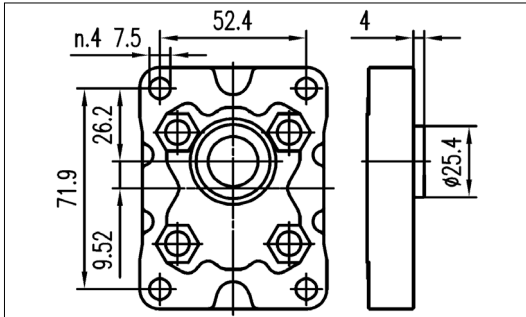

1

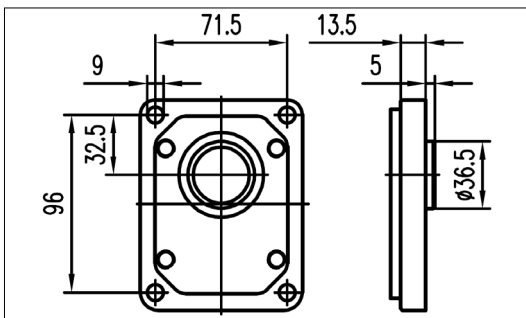

3

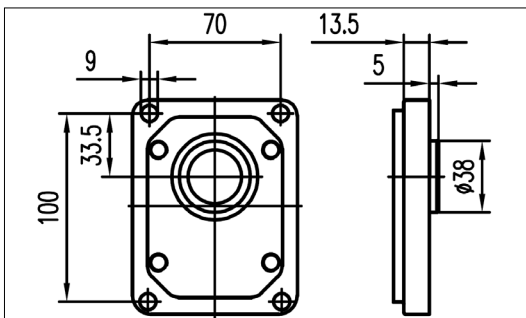

8

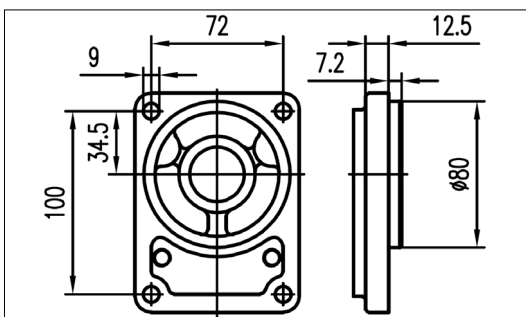

6

SHAFTS

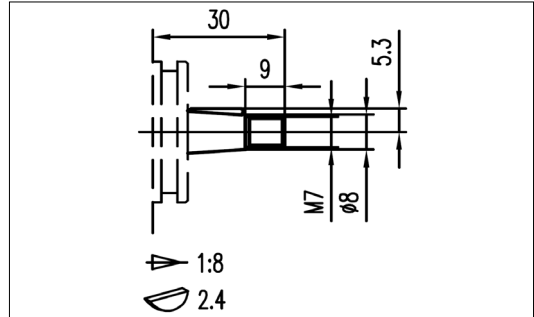

1

Max. Torque

20 Nm

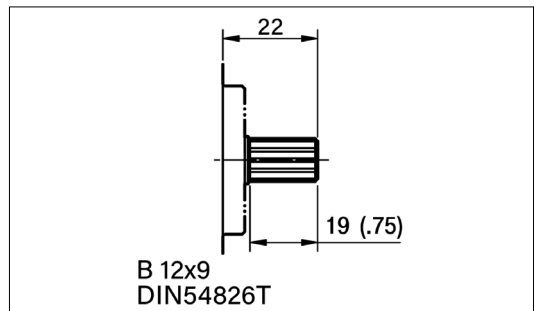

7

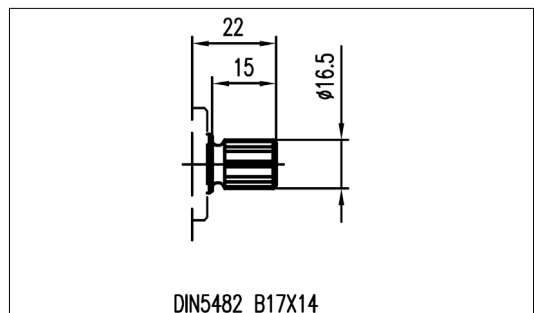

12

Max. Torque

150 Nm

FRONT COVERS

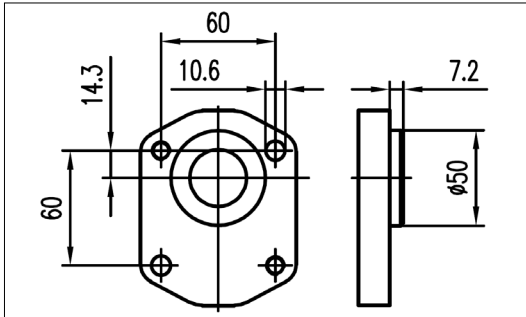

4

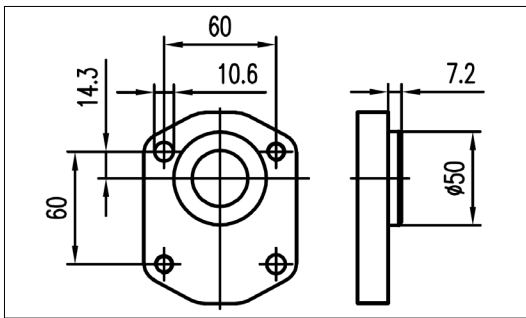

9

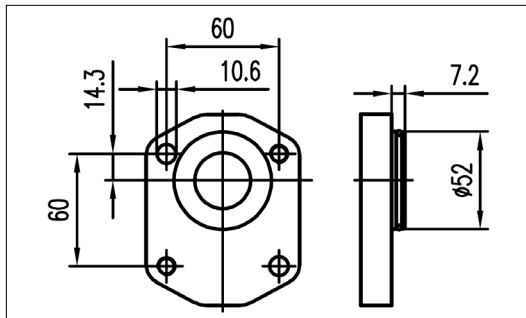

10

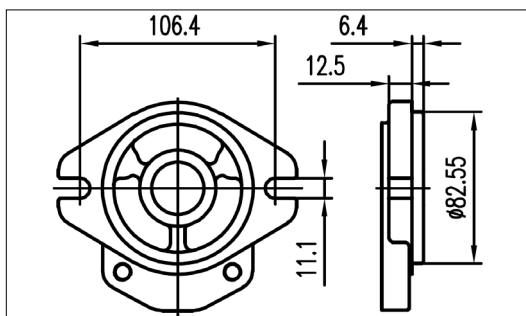

2

SHAFTS

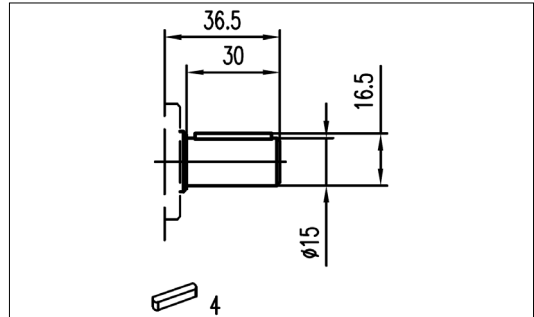

9

Max. Torque

135 Nm

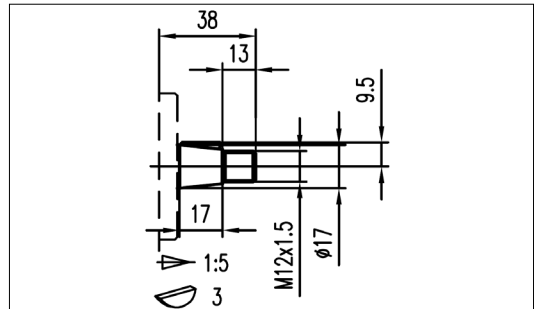

8

Max. Torque

180 Nm

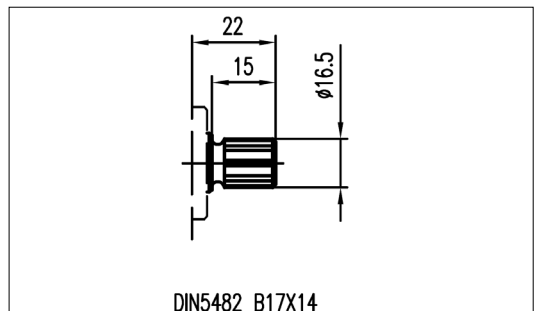

11

Max. Torque

185 Nm

FRONT COVERS

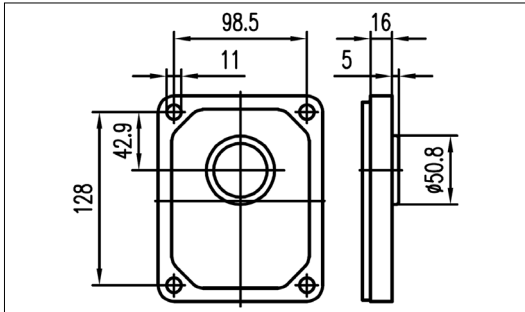

5

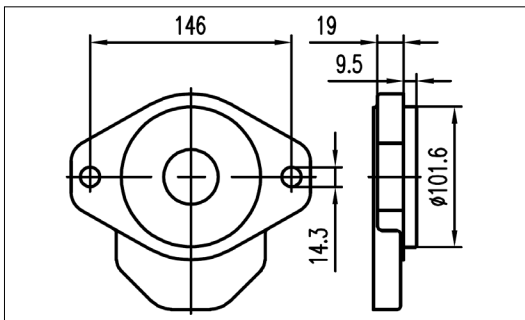

7

SHAFTS

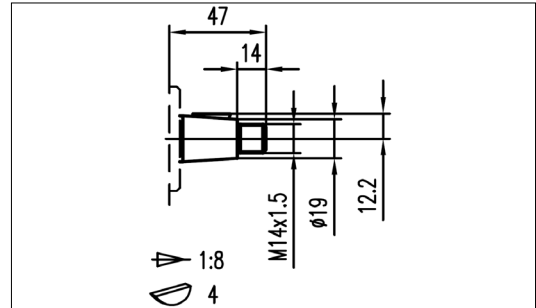

2

Max. Torque

300 Nm

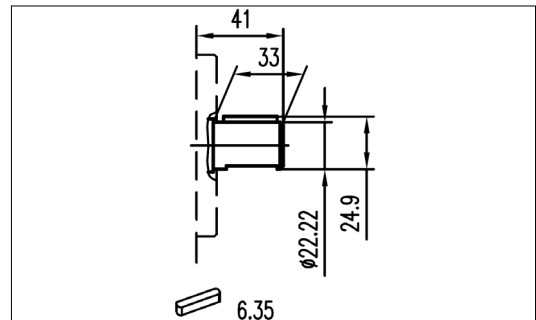

14

Max. Torque

400 Nm

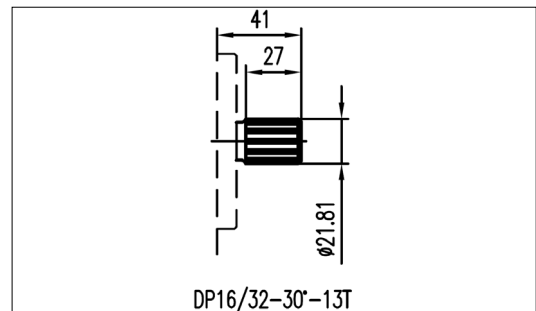

15

Max. Torque

500 Nm

PORTS

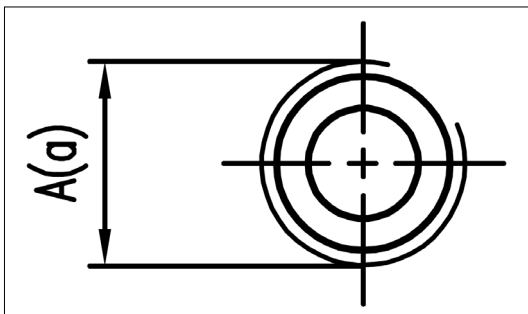

3838

INLET	OUTLET
A	a
G3/8	G3/8

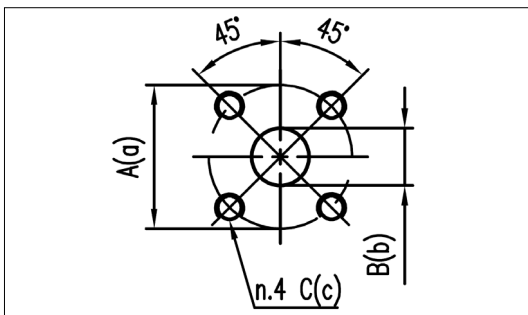

3030

INLET			OUTLET		
A	B	C	a	b	c
30	12	M6	30	12	M6

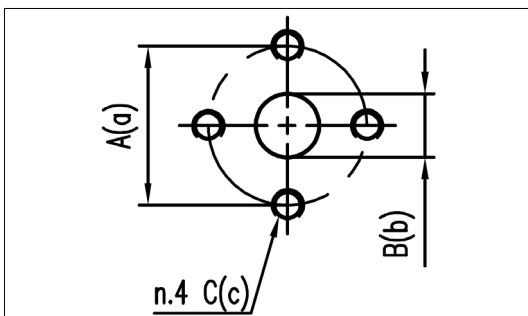

3030R

INLET			OUTLET		
A	B	C	a	b	c
30	12	M6	30	12	M6

PORTS

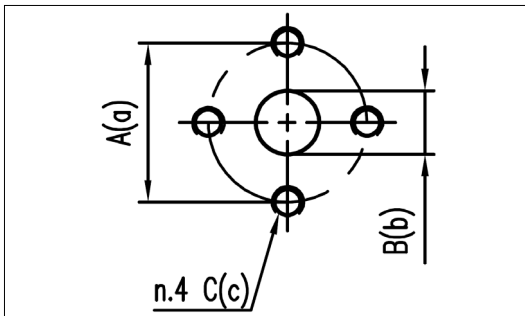

PORTS CODE	INLET			OUTLET		
	A	B	C	a	b	c
3030	30	13	M6	30	13	M6
4030	40	20	M8	30	13	M6
4040	40	21	M8	40	19	M8

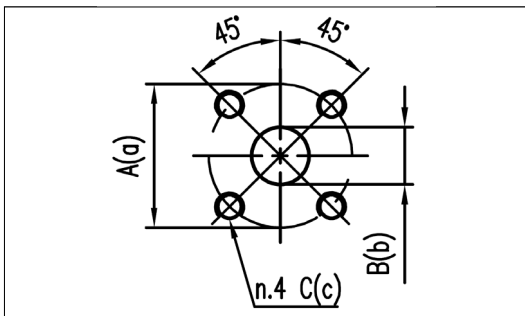

PORTS CODE	INLET	OUTLET
	A	a
1238	G1/2	G3/8
3412	G3/4	G1/2
1034	G1	G3/4

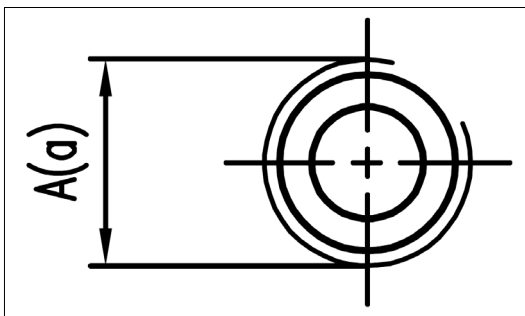

PORTS CODE	INLET	OUTLET
	A	a
10 34	G1	G3/4
114 10	G1 1/4	G1
112 114	G1 1/2	G1 1/4

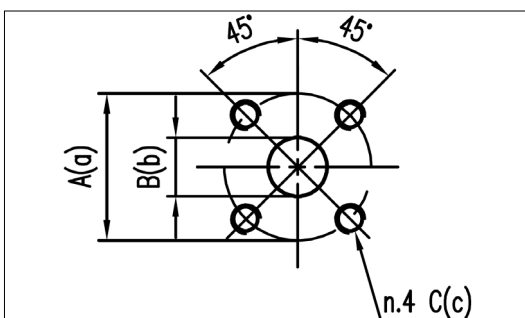

PORTS CODE	INLET			OUTLET		
	A	B	C	a	b	c
4035	40	20	M6	35	15	M6

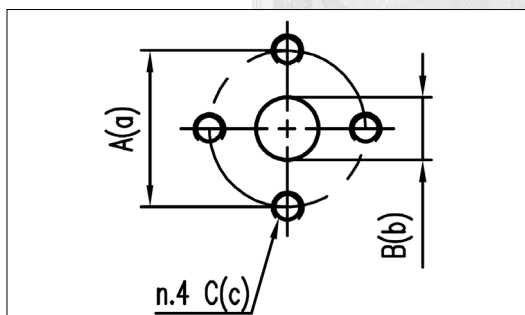

PORTS CODE	INLET			OUTLET		
	A	B	C	a	b	c
51 40	51	25	M10	40	18	M8
62 51	62	33	M10	51	27	M10
62 62	62	33	M10	62	33	M10

ASSEMBLED PUMP

Multiple pump	Group	Size	Shaft *	Flange *	Inlet port *	Outlet port *	Rotation	Standard Version
---------------	-------	------	---------	----------	--------------	---------------	----------	------------------

VNKBM	3		25	
	2		4	30
	1	1.1	6	33
		1.3	8	39
		1.6	10	46
		1.8	12	50
		2.1	14	55
		2.7	16	63
		3.2	18	70
		3.7	20	80
		4.2	23	90
		5	25	
		5.8	30	
		7		
		8		

* see specifications of shafts, flanges and ports in pages 42, 43, 44, 45, 46.

C	Clockwise	S
A	Counter clockwise	H
		J
		W
		R

EXAMPLE

Multiple pump with driver pump G3 50cc cover flange cylindrical shaft Ø22, FLANGED PORTS, intermediate pump G2 16cc flanged port and final pump G1 4cc with thread ports, clock wise rotation two inlet and two outlet.

VNKBM-3-2-1-50-16-4-14-7-51-40-40-30-38-38-C-S

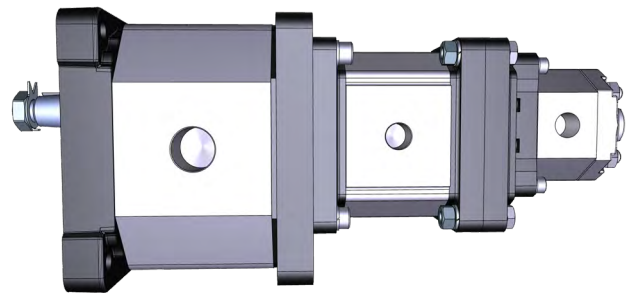

VINCKE



your Hydraulic Brand

