

NoyFar

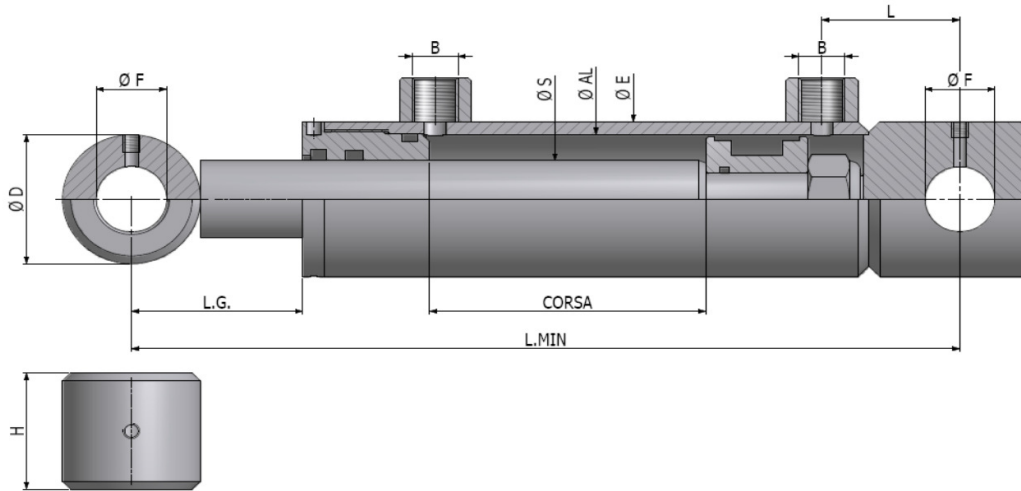

CILINDRO DOPPIO EFFETTO TIPO FDA

CODICE	Ø E	Ø AL	Ø S	CORSA	L. MIN	L.G.	Ø F	Ø D	H	B	L
NYFDA1050	35	25	16	50	160	21	12,1	25	25	1/4"	24
NYFDA1100				100	210						
NYFDA1150				150	260						
NYFDA1200				200	310						
NYFDA2050	42	32	20	50	205	54	16,25	30	35	1/4"	32
NYFDA2100				100	255						
NYFDA2150				150	305						
NYFDA2200				200	355						
NYFDA2250				250	405						
NYFDA2300	300	455									
NYFDA3100	50	40	25	100	270	57	20,25	40	40	3/8"	40
NYFDA3200				200	370						
NYFDA3300				300	470						
NYFDA3400				400	570						
NYFDA3500				500	670						
NYFDA3600				600	770						
NYFDA4100	60	50	30	100	300	67	25,5	50	45	3/8"	50
NYFDA4200				200	400						
NYFDA4300				300	500						
NYFDA4400				400	600						
NYFDA4500				500	700						
NYFDA4600				600	800						
NYFDA5200	70	60	30	200	400	63	25,5	50	45	3/8"	43
NYFDA5300				300	500						
NYFDA5400				400	600						
NYFDA5500				500	700						
NYFDA5600				600	800						
NYFDA5700				700	900						
NYFDA6200	80	70	40	200	410	56	30,5	50	55	3/8"	45
NYFDA6300				300	510						
NYFDA6400				400	610						
NYFDA6500				500	710						
NYFDA6600				600	810						
NYFDA6700				700	910						
NYFDA7200	92	80	40	200	410	44	30,5	50	55	3/8"	45
NYFDA7300				300	510						
NYFDA7400				400	610						
NYFDA7500				500	710						
NYFDA7600				600	810						
NYFDA7700				700	910						
NYFDA8200	102	90	50	200	415	60	30,5	65	70	1/2"	50
NYFDA8300				300	515						
NYFDA8400				400	615						
NYFDA8500				500	715						
NYFDA8600				600	815						
NYFDA8700				700	915						
NYFDA9200	112	100	50	200	415	60	30,5	65	70	1/2"	50
NYFDA9300				300	515						
NYFDA9400				400	615						
NYFDA9500				500	715						
NYFDA9600				600	815						
NYFDA9700				700	915						