



Spare parts catalogue

Winch
SW195 JO

DINAMIC OIL S.p.A.

Via Togliatti, 15
41030 Bomporto (MO)
tel +39.059.812611
fax +39.059.812603
dinamicoil@dinamicoil.it

Spare parts catalogue No.

L507

Logbook code

829600023V

Edition

12/11/2015

Revision

0



Table index	<i>Winch</i>	SW195 JO
	<i>Logbook code</i>	829600023V

Page	Table code	Table heading
3	829600023V	WINCH SW195 JO SLM
4	829600023V-1	WINCH SW195 JO SLM
5	905960200	CABLE PRESS KIT WINCH SW195 JO
6	905960200-1	CABLE PRESS KIT WINCH SW195 JO

Pos	Code	Qty	Description
1	2030052100	1	SOLAR GEAR RE210 4,2
2	02741008	1	BRONZE PAD Ø20,6X8
3	421105700	1	CLIP RING DIA 21MM
4	410027900	8	HEX SOCKET HEAD CAP SCREW M10X110 12.9 GEOMET 500B
5	423207800	8	WASHER SCHNORR VS10 GALVANIZED
6	2030031800	1	SUN GEAR 2ST R 3,6 RE 510
7	02231009	1	RING GEAR RE210/240 1 ST
8	99121500	1	GEAR SUBASSEMBLY RE 510 3,6 '00
9	410045500	12	SCREW TCEI M10X80 12.9 GEOMET 500B
10	406015000	2	O-RING 2-171
11	421002700	2	SHAFT SEEGER Ø58
12	024410154	1	TRANSMISSION SHAFT
13	410424500	22	SCREW TCEI M12X35 12.9 GEOMET 500B
14	023310165	1	MOTOR SIDE CARRIER FLANGE
15	410428500	36	SCREW TCEI M18X55 12.9 GEOMET 500B
16	415031900	1	SEAL RING 240X270X15 BASL
17	406061700	1	V-RING NBR VA 325
18	029918175	1	MOTOR SIDE SUPPORT
19	400023400	1	BALL BEARING 6040 TIPO A
20	026310221	1	SPLINED COUPLING
21	410039300	36	HEX SOCKET HEAD CAP SCREW M24X60 12.9 GEOMET 500B
22	029911240	1	MOTOR SIDE FLANGE
23	406032200	2	O-RING 2-389
24	421107500	1	HOLE SEEGER UNI 7437 Ø310
25	410406900	12	HEX SOCKET HEAD CAP SCREW M12X75 12.9 UNI 5931
26	410091000	6	HEX SOCKET HEAD CAP SCREW M16X50 12.9 GEOMET 500B
27	02411012	3	ROPE PRESS FIXING Ø32 ARG.SW220
28	02231028	1	RING GEAR RE1020
29	410021500	21	TCEI SCREW M16X130 12.9 UNI 5931
30	410408400	3	TCEI SCREW M16X110 12.9 UNI 5931
31	02611123	1	SUN GEAR R=1:5.1 RE 1020
32	02231015	1	RING GEAR RE2520-3000
33	410093000	36	HEX SOCKET HEAD CAP SCREW M18X160 12.9 UNI 5931
34	99525900	1	GEAR SUBASSEMBLY RE 8000 FS R=1:4 WINCH SW195 JO
35	02611486	1	SUN GEAR R 1:4 X RE 8000
36	02741027	1	PAD RE 2520-5000 Ø32X12
37	410250100	3	HEX HEAD CAP SCREW M14X40 10.9 UNI-EN 24017
38	023710164	1	REACTION BAR
39	402005100	2	FIFTH WHEEL AS 140X180X1

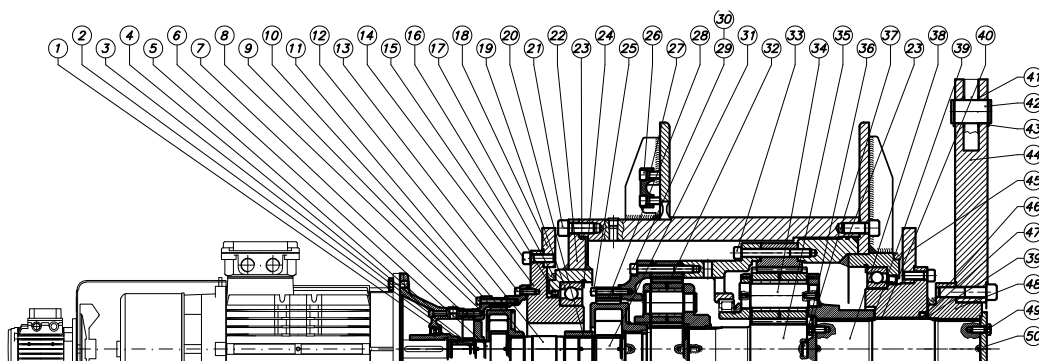

829600023V

Winch

SW195 JO

Logbook code

829600023V

Pos	Code	Qty	Description
40	405029000	1	BUSH FRITEX 316 $\varnothing 140 \times \varnothing 145$ L=100
41	427023100	4	THICKNESS SHIM ADJUSTMENT 55X70X1
42	026010544	1	CYLINDER FIXING PIN
43	421011200	2	SHAFT SEEGER $\varnothing 55$ INOX
44	025310165	1	INTEGRAL REACTION ARM
45	029918176	1	GEAR SIDE SUPPORT
46	415091700	1	DUST RING VA220 (D.210-235)
47	415015600	1	SEAL RING 140X170X15 BASL
48	023710163	1	REACTION HUB
49	410416600	3	HEX HEAD CAP SCREW M14X40 10.9 GEOMET 500B
50	025510226	1	BAR CLOSING END PLATE

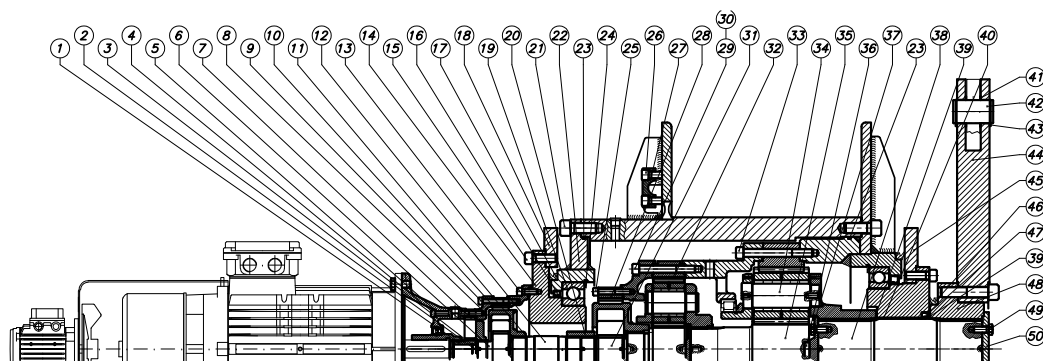

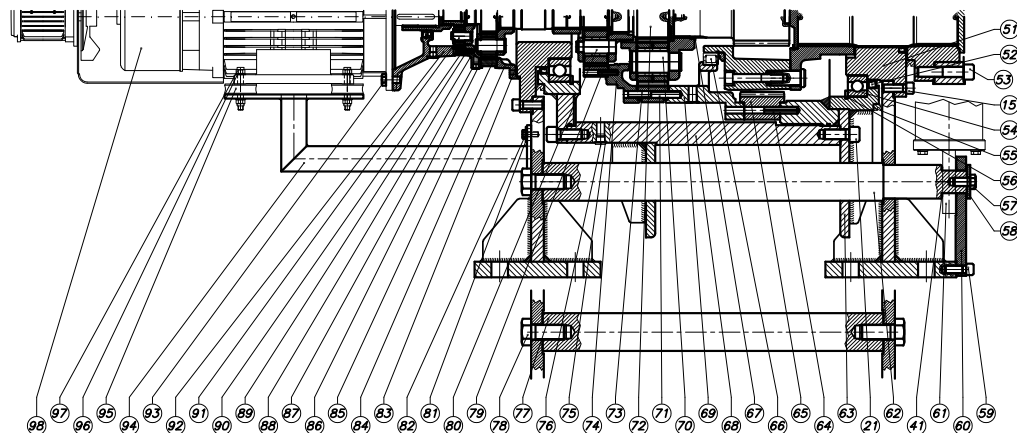

Pos	Code	Qty	Description
15	410428500	36	SCREW TCEI M18X55 12.9 GEOMET 500B
21	410039300	36	HEX SOCKET HEAD CAP SCREW M24X60 12.9 GEOMET 500B
41	427023100	4	THICKNESS SHIM ADJUSTMENT 55X70X1
51	023310164	1	GEARBOX SIDE FLANGE
52	415032000	1	SEAL RING 300X340X18 BASL
53	410097000	18	SCREW TCEI M24X110 12.9 GEOMET 500B
54	400028900	1	BALL BEARING 61956
55	406063700	1	V-RING NBR VA 400
56	421108200	1	HOLE SEEGER UNI 7437 Ø380
57	410431300	2	SCREW TE M20X40 10.9 GEOMET 500B
58	027302101	2	BLOCK WASHER RAIL
59	410417000	10	HEX SOCKET HEAD CAP SCREW M18X50 12.9 GEOMET 500B
60	024910324	2	CYLINDER SUPPORT
61	444012700	1	LOAD LIMITER SIEMENS A-H-100105
62	024510467	2	CYLINDER FIXING UPPER RAIL
63	029912291	1	GEAR SIDE FLANGE
64	434008500	3	ELASTIC PIN SPIROL Ø16X80 UNI6875
65	02231084	1	RING GEAR RE6000/RE8000
66	401006800	1	BEARING
67	421001900	1	SHAFT SEEGER Ø100
68	029910455	1	SMOOTH DRUM
69	02731142	1	INTERMEDIATE FLANGE RE 6520-8000
70	99307500	1	GEAR SUBASSEMBLY RE 3000 R=1:4
71	434011500	3	DOWEL PIN DIA 16X70 UNI6875
72	026110175	1	SUN GEAR 1:4 RE2520/3000 X RE1020
73	434009300	3	ELASTIC PIN SPIROL Ø16X55 UNI6875
74	02731047	1	INTERMEDIATE FLANGE RE3000/RE2520 FOR RE1020/810
75	423000700	4	SOFT COPPER WASHER 1/2" (21X27X2)
76	442039200	4	PLUG TCEI 1/2"GAS INOX
77	024510466	2	UPPER RAIL
78	410429800	6	SCREW TE M36X80 10.9 GEOMET 500B
79	434002700	4	ELASTIC PIN SPIROL Ø12X45 UNI6875
80	99345100	1	GEAR SUBASSEMBLY RE 1020 R1:5.1 VERS.2010
81	423108600	4	WASHER 12,5X36X3 UNI 6593 INOX A4
82	410024800	4	SCREW TE M12X30 10.9 GEOMET 500B
83	406013200	1	O-RING 2-177
84	02731043	1	INTERMEDIATE FLANGE RE810/1020 PER RE310/5
85	2030030600	1	RING GEAR RE500
86	442042000	2	HEX SOCKET HEAD CAP PLUG 1/4"GAS DIN 908 INOX

Pos	Code	Qty	Description
87	423000300	2	SOFT COPPER WASHER 1/4" UNI6953
88	2030022400	1	INTERMEDIATE FLANGE RE310/510 FOR RE110/210
89	434002400	2	ELASTIC PIN SPIROL Ø10X40 UNI6875
90	406018200	2	O-RING 147X2,62 N70-N003
91	99103700	1	GEAR SUBASSEMBLY RE 210 N 4,26
92	K0700AD01	1	ME-160 RE 110/210/240
93	410422500	4	HEX HEAD CAP SCREW M16X35 10.9 GEOMET 500B
94	029918174	1	ELECTRIC MOTOR SUPPORT
95	415123700	4	SILENT BLOCK Ø75X25 M12
96	423205100	8	WASHER C50 Ø12 ZINCATE UNI 5714
97	413103400	8	AUTOBLOCK NUT M12 UNI7474 INOX
98	425056100	1	ELECTRICAL MOTOR FOR WINCH SW195 JO

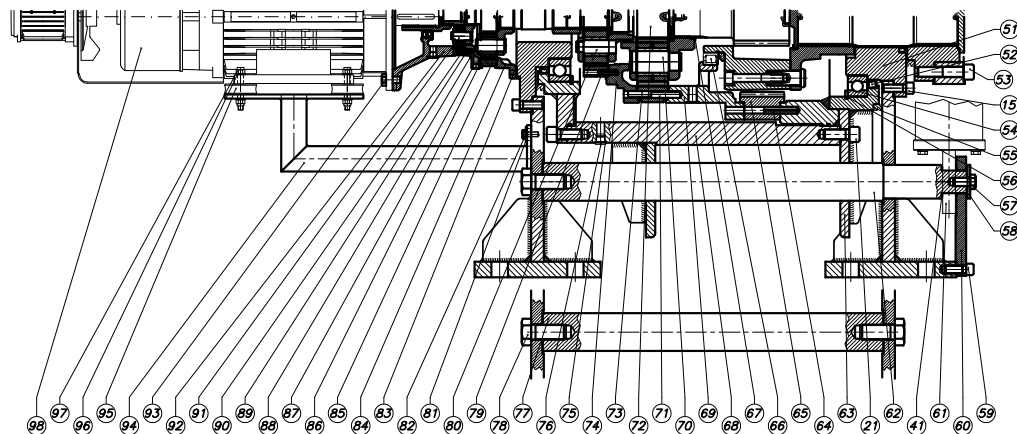

Pos	Code	Qty	Description
1	413002900	1	NUT M8 UNI 5588 INOX A2-70
2	410019400	1	SCREW TE M8X30 INOX A2-70
3	01020003	1	MICROSWITCH SUPPORT PLATE
4	410150600	2	HEX SOCKET HEAD CAP SCREW M8X20 INOX A2-70
5	905000102	1	MICROSWITCH KIT
8	413002100	8	NUT M10 UNI 5588 INOX
9	445000700	4	M10 EYE TIE-RODS L=130 UNI6058
22	410300100	6	DOWEL M10X12 UNI5927 PUNTA CONICA
23	023910104	2	CABLE PRESS REACTION LEVER SWD G210 HE
24	418204800	4	TRACTION SPRING DIM T43320 INOX

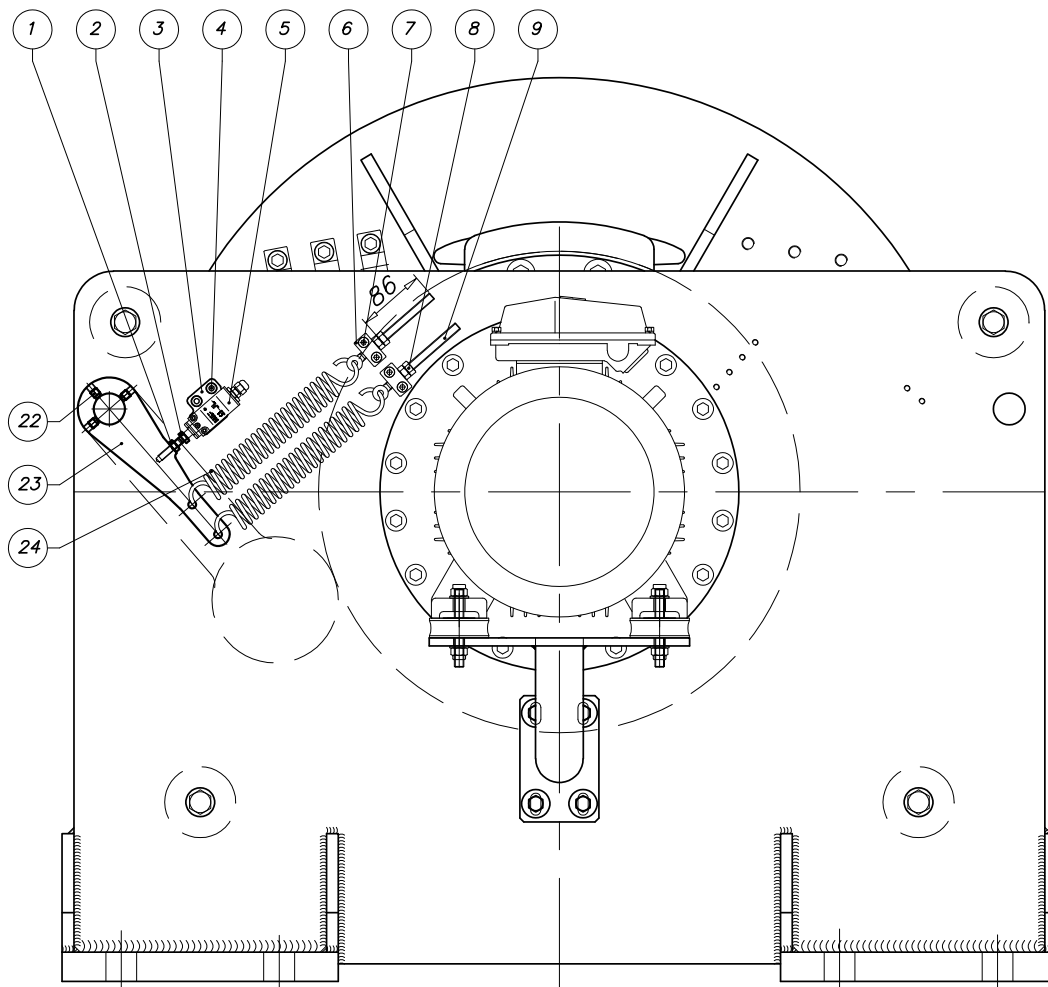

Pos	Code	Qty	Description
10	01021100	4	MOTOR SPACER F12-80/H1B
11	027410117	17	THICKNESS SHIM ADJUSTMENT 40.2X67.5X1
12	026010547	1	Ø40 CABLE PRESS PIN
13	434016800	4	ELASTIC PIN Ø10X40 UNI6873 INOX
14	026010546	1	REINFORCEMENT BAR CABLEPRESS SW195 JO
15	023910108	2	CABLE PRESS ARM SW195 JO
16	410152400	2	SCREW TCEI M16X45 A2-70 INOX
17	010105352	1	DISCHARGED ROLLER L.140 Ø160X180
18	026010545	1	ROLLER PIN Ø40X426
19	010105353	1	CENTRAL ROLLER Ø160X124
20	010105354	1	LATERAL ROLLER Ø160X80
21	400010400	6	BALL BEARING 6008 2RS

