

Manual of use and maintenance
S15 FH

Translation of the original manual

Winch code: **92 16 10 06 FE**
Manual code: **M157**

Edition: **07/2013**
rev0 del 01/10/2012

Index

1 – GENERAL INFORMATIONS	4
1.1 – Manufacturer’s identification data	4
1.2 – Winch identification data	4
1.3 – Using this instruction manual	4
1.4 – Exclusion of responsibility	4
1.5 – Instructions for technical assistance	5
1.6 – Receiving.....	5
1.7 – Warranty.....	5
1.8 – Standards and applied laws	5
1.9 – Safety symbols used in this manual.....	5
2 – TECHNICAL INFORMATIONS.....	6
2.1 – Main parts and general winch description.....	6
2.2 – Description of machine functions	6
2.3 – Permitted use	6
2.4 – Uses not permitted	6
2.5 – Environmental conditions	6
2.6 – Safety devices	6
2.7 – Residual risks.....	6
2.8 – Noise	6
2.9 – Electro-magnetic field.....	6
2.10 – Overall dimensions.....	7
2.11 – Technical data.....	8
3 – SAFETY	9
3.1 – General safety instructions.....	9
4 – TRANSPORTING, HANDLING AND INSTALLATION	10
4.1 – Packing the machine.....	10
4.2 – Handling - Storage	10
4.3 – Winch movement	11
4.4 – Assembly on base plate	11
4.5 – Installation	12
4.6 – Hydraulic diagram	13
4.7 – Checks	16
4.8 – Cable mounting.....	17
4.9 – Pulleys.....	18
5 – INFORMATION ABOUT ADJUSTMENTS.....	19
5.1 – Adjustments	19
6 – START UP INFORMATION	20
6.1 – Start up.....	20
7 – MAINTENANCE INFORMATION.....	21
7.1 – Warning.....	21

7.2 – Maintenance schedule	21
7.3 – Cable	21
7.4 – Lubrication.....	22
7.5 – Cleaning operations	24
7.6 – Scrapping and disposal.....	24
8 – PROBLEMS AND SOLUTIONS.....	25
8.1 – Troubleshooting	25
9 – PARTS REPLACEMENT	26
9.1 – Cable replacement.....	26
10 – ANALYSIS OF THE RESIDUAL RISKS	27
11 – NOTES.....	28





1 – GENERAL INFORMATIONS

1.1 – Manufacturer's identification data

DINAMIC OIL S.p.a.

Via Togliatti, 15
41030 Bomporto (Mo) - Italy
telefono 059/812611 - telefax: 059/812606
e-mail: dinamicoil@dinamicoil.it

1.2 – Winch identification data

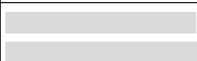
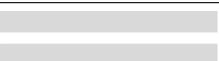
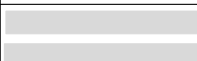
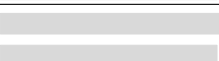
		
	a	
	b	
	c	
	d	

- Plate details

- a = Model
- b = Serial nr.
- c = Max delivery
- d = Max pull
- e = Code
- f = Year
- g = Max speed
- h = Hoisting pressure

Information

Under no circumstances must the data shown on the identification plate be altered.

1.3 – Using this instruction manual

This manual contains the necessary information enabling the operator to familiarize and correctly use the winch (also simply described as "the machine", although according to Directive 2006/42/CE, the winch has been classified as partly completed machine).

The information contained is intended for skilled operators (1).

The original instructions are supplied by the manufacturer in Italian.

To fulfil legal or commercial requirements, the original instructions may be supplied by the manufacturer in other languages.

If there are any doubts, whatsoever, concerning the correct interpretation of the instructions contained in this manual, immediately contact the manufacturer for any necessary clarifications.

To facilitate the consultation of the manual, it has been divided into chapters of major concepts.

For quick searches please consult the index.

Reproduction or publication, in part or in whole, of the information contained in this manual is prohibited without written authorization given by the manufacturer.

Using this instruction manual, for purposes other than those described, without written authorization given by the Manufacturer, is prohibited.

Any violation will be prosecuted according to the law.

(1) Only experienced people having the proper technical ability and knowledge of regulations and laws will be able to carry out the necessary operations and to identify and avoid possible damages during handling, installation, operation and maintenance of the machine.

1.4 – Exclusion of responsibility

The manufacturer is released from any responsibility for damages deriving from:

- incorrect installation or which is not in accordance with applicable laws;
- use of the machine by unauthorized and/or untrained personnel;
- total or partial instruction disregarding;
- lack of maintenance;
- unauthorized modifications or repairs;
- non-designated uses;
- use of non-original spare parts and/or parts that are not specific to the model;
- environmental circumstances beyond the manufacturer's control.

1.5 – Instructions for technical assistance

In case of machine malfunction or failure, for which special technical assistance is required and for all spare parts requests, contact directly the manufacturer or the Reseller by phone or fax.

1.6 – Receiving

If any damages, faults or missing pieces are noted, contact **Dinamic Oil S.p.a.** - Sales Office, immediately - Winch Department - by phone 059/812611 or by fax 059/812606.

1.7 – Warranty

- **Dinamic Oil S.p.a.** warrants that its products are free from all defects in materials or workmanship during the warranty period indicated on the order confirmation Dinamic Oil at the moment of purchase.

- During the warranty period **Dinamic Oil S.p.a.** will repair or replace all parts or components that are unserviceable due to ascertained defects in materials or workmanship.

Under this warranty, any defective pieces must be sent to **Dinamic Oil S.p.a.** which will examine them so as to determine their cause.

- This warranty is strictly limited to the repair or replacement of products. Under no circumstances will the manufacturer accept claims from customer demanding reimbursement for direct or indirect damages of any nature.

The merchandise may be returned only when previously authorized by **Dinamic Oil S.p.a.**

- This warranty does not extend to “O” rings or gaskets in general.

- This warranty does not cover any costs associated with the installation or removal of defective parts from the purchaser’s equipment.

- This warranty does not extend to any products that have been repaired, modified or simply disassembled, even partially.

- This warranty does not extend to any products that have been subject to misuse or abuse, incorrect or careless assembly and tapering.

- This warranty recognized by **Dinamic Oil S.p.a.** through its authorized sellers, disclaims all other warranties of any nature whatsoever.

1.8 – Standards and applied laws

The machine was designed and constructed under current directives 2006/42/CE and the following normes: ISO 4301/01; FEM 1.001 3rd edition (point 2,3,4,5,8).

1.9 – Safety symbols used in this manual

The following symbols will also appear throughout this instruction manual. For safety purposes, these symbols aim to highlight the operations which are considered safety hazards. Therefore, it is absolutely indispensable that the instructions highlighted by these symbols be respected.



The information and procedures indicated by this symbol which are not strictly respected will result in immediate death or serious personal injuries.



The information and procedures indicated by this symbol which are not strictly respected may result in death or severe personal injuries.



The information and procedures indicated by this symbol which are not strictly respected may result in minor personal injuries or damages to the machine.



Indicates important procedures and instructions.

2 – TECHNICAL INFORMATIONS

2.1 – Main parts and general winch description

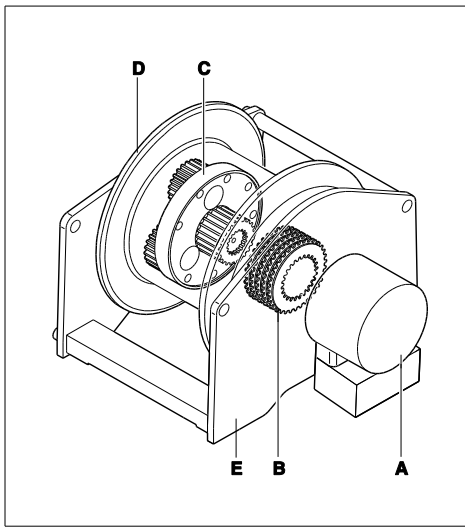

- Legend

- A = Hydraulic motor
- B = Negative parking brake
- C = Planetary reduction gear
- D = Drum
- E = Support structure

The winch is composed of a drum (in which an planetary reduction gear and a negative parking brake are inserted) driven by a hydraulic motor, around which the rope for load hoisting is wound: the whole unit is installed on a support frame.

2.2 – Description of machine functions

The winch is commanded by the distributor of the operative machine on which it is installed. The rotation of the drum winds and unwinds the rope to which the load is applied. The brake is released when the motor is started and is activated when the motor is stopped.

2.3 – Permitted use

The winch is designed to raise and lower loads by winding and unwinding the cable around the drum. The use of the winch with superior values to those listed in the technical data is considered "**improper use**" and therefore "**not admitted**"; insofar the builder declines every responsibility in relation to the damages eventually provoked to people or to things and cancels the warranty.

2.4 – Uses not permitted

Never use the winch to lift and transport people. It is forbidden to use the winch before machine on which it is mounted has been declared compliant to the dispositions of the Directive 2006/42/CE.

2.5 – Environmental conditions

Room temperature for a proper use: - 10°C; + 40°C.

2.6 – Safety devices

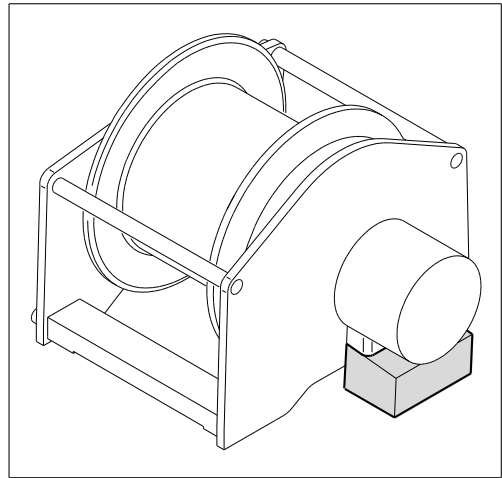

Valve for stopping and controlling the lowering

Fluid controlled, mounted directly on the hydraulic motor, this part is essential for the safe functioning of the winch. It prevents the load slipping out of the motor's control during lowering.

2.7 – Residual risks

Despite the observance of all safety norms and the employment according to the rules described in the manual, there can still be some residual risks among which the most recurrent are:

- friction;
- crushing between rope and drum;
- inverse rotation of the drum by human error;
- ejection of fluids due to the spillage of the oil in pressure.

Keep in mind that the use of an any machine implicates some risks. Face every type of operation with the maximum attention and concentration.

2.8 – Noise

The level of noise emissions detected is not relevant.

2.9 – Electro-magnetic field

The electro-magnetic discharges of the winch with cable press - limit switch and load limiter are not significant.

2.10 – Overall dimensions

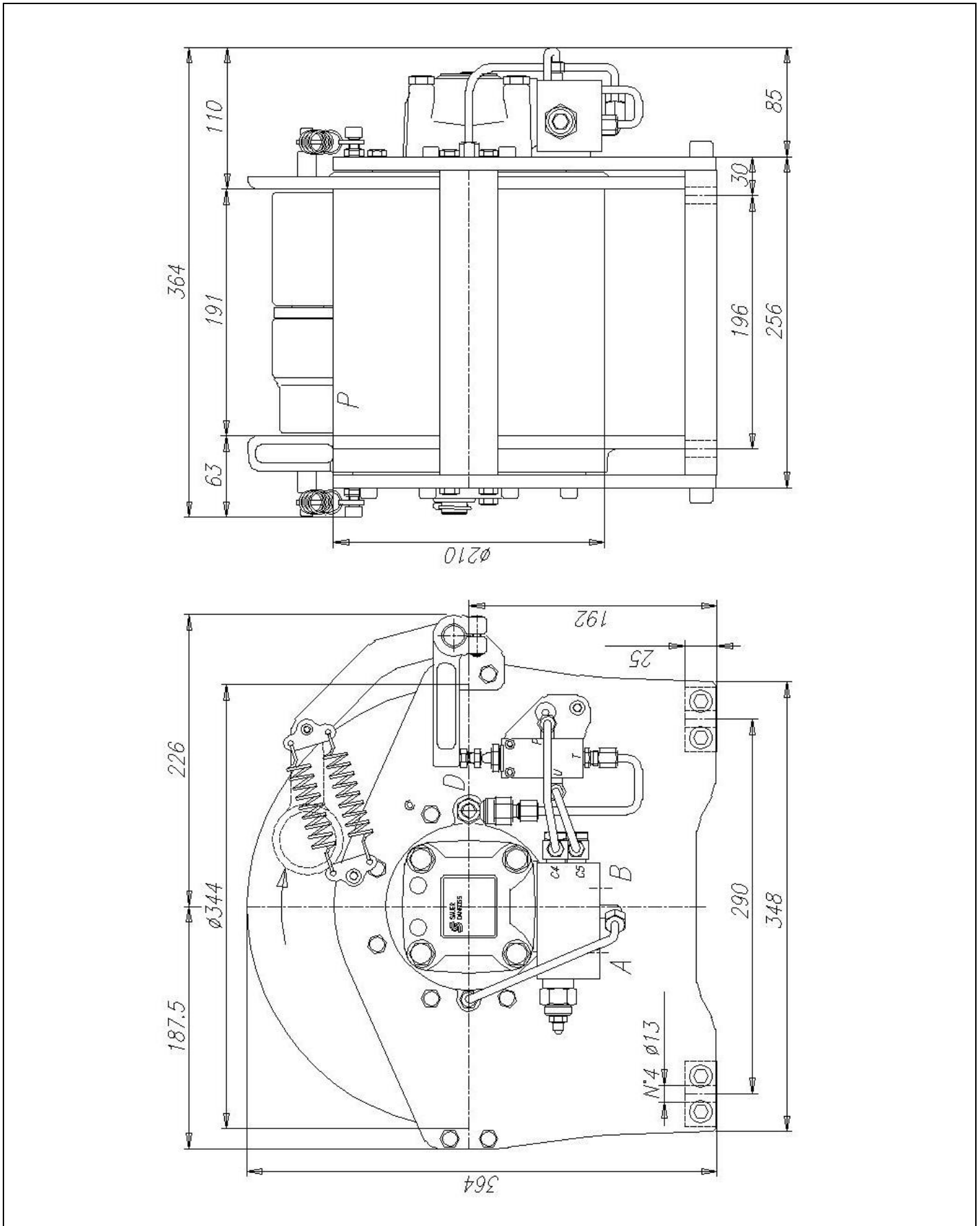

V2 (A) = Hoisting line: 1/2" BSP
V1 (B) = Lowering line: 1/2" BSP

D = Drain line: 1/4" BSP
P = Lubrication oil plug: 3/8" BSP

2.11 – Technical data

Hydraulic motor:	SAUER DANFOSS OMSU
Motor displacement:	160 cm ³
Maximum and minimum oil flow:	45/10 L/1'
Maximum counterpressure on the return line:	5 bar
Hoisting pressure:	205 bar
Negative brake:	static torque of 74 daNm (with back pressure of 1 bar)
Minimum brake release pressure:	25 bar
Secondary safety brake:	not present
Planetary reduction:	ratio 1:5,77
Drum rotation direction(hoisting):	clockwise
Reduction lubrication oil:	HLP ISO VG 46 – 0,9 L
Fixing screws:	M12 – 10.9 class (see “Tightening torques” chart)
Total weight of winch complete with lubricant:	80 kg
Recommended rope diameter:	10 mm
The winch is classified according to UNI ISO 4301/1	

Rope layer	n°	1	2	3	4	5	6
Total line pull	daNm	2000	1850	1700	1570		
Rope speed with capacity 45 L/1'	m/1'	32	35	38	41		
Smooth drum rope capacity	m	12	26	41	57		
Grooved drum rope capacity	m						

- Tightening torques

	Values for driving torques (Nm)		
	8.8 class	10.9 class	12.9 class
M10	50	73	86
M12	86	127	148
M14	137	201	235
M16	214	314	368
M18	306	435	509
M20	432	615	719
M22	592	843	987
M24	744	1060	1240
M27	1100	1570	1840
M30	1500	2130	2500

3 – SAFETY

3.1 – General safety instructions

- Read this manual carefully before attempting installation, use and maintenance operations.
- The user must be familiar with applicable safety rules and use modes of both the operating machine and the winch installed, as he is responsible for his own safety as well as for any other person present near the machine working area.
- All the operators must be suitably trained to use, adjust and operate of both the operating machine and the winch installed.
- Do not allow unauthorized personnel to use this machine.
- Do not start the machine, if it is faulty.
- Do not search for hydraulic leakage with bare hands, use a piece of paper or wood instead.
- A fluid coming from a very small hole might be almost invisible, and yet sufficient to penetrate the skin.
- If the fluid comes in contact with the skin, seek medical assistance immediately, for there might be risk of infection or skin disease.
- Before removing any caps, plugs, or flexible tubes, make sure that there is no pressure in the hydraulic circuit.

4 – TRANSPORTING, HANDLING AND INSTALLATION

4.1 – Packing the machine

The packing of the machine is done according to the agreements made with the Customer, taking into account the distance and type of transport chosen.

In general the winches are packed in wooden boxes with wood joists to facilitate harnessing and lifting. Packing varies in relation to the quantity and type of product.

The weight and dimensions are indicated in the transport documents or on the package itself.



Do not tilt or turn the package upside down while lifting or during transport.

4.2 – Handling - Storage

Use suitable means of transport to hoist and move the packed unit, taking into account the type of packing.

If the package is moved with a fork-lift truck, make sure the weight is balanced on the forks.

If the packages are moved with a hoist and, in any case, with a hook, make sure that the load is balanced in the sling.

Use lifting accessories that are suitable and legally certified.

While hoisting the unit and positioning it, take care not to let it swing too much to prevent it hitting something.

The storage area must not be excessively damp or dusty. The ambient temperature must be between - 20 °C and + 70 °C with a maximum humidity level of 90%, with no condensation.

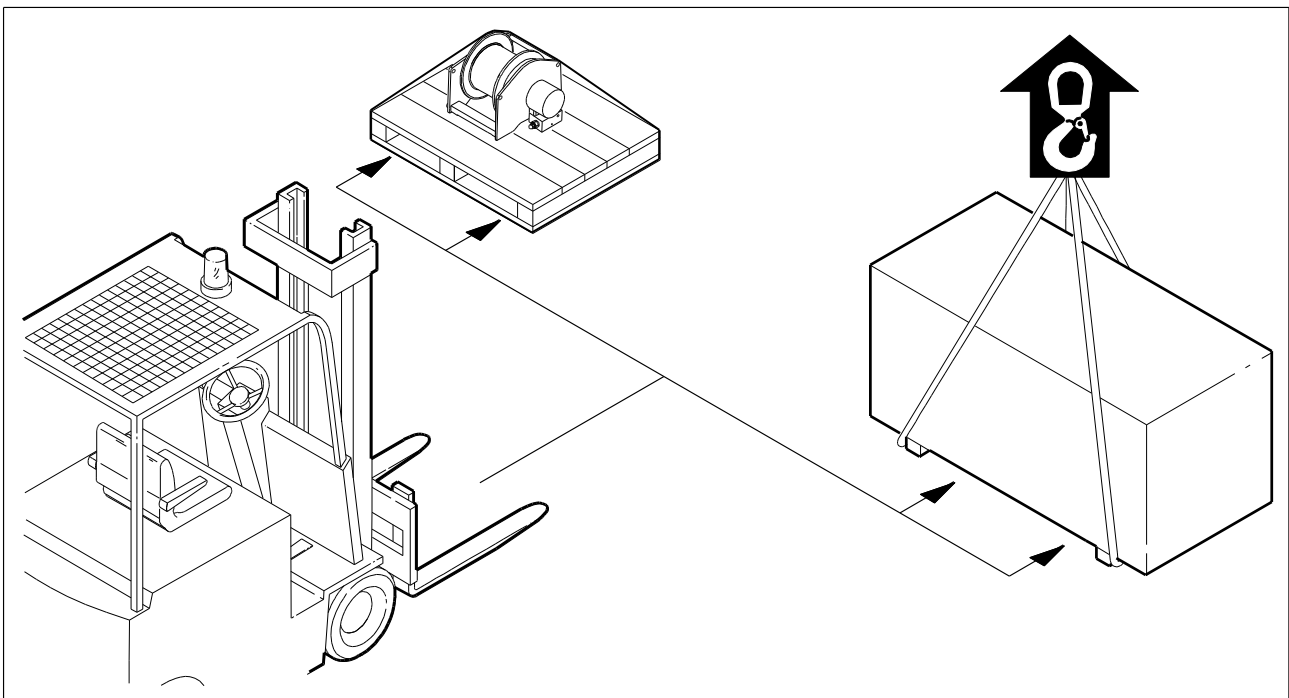

4.3 – Winch movement

For the hoisting procedures, strap the winch using two belts, which must be wrapped around the ends of the drum (fig. A), or hook it on at the indicated points (fig. B) if present.

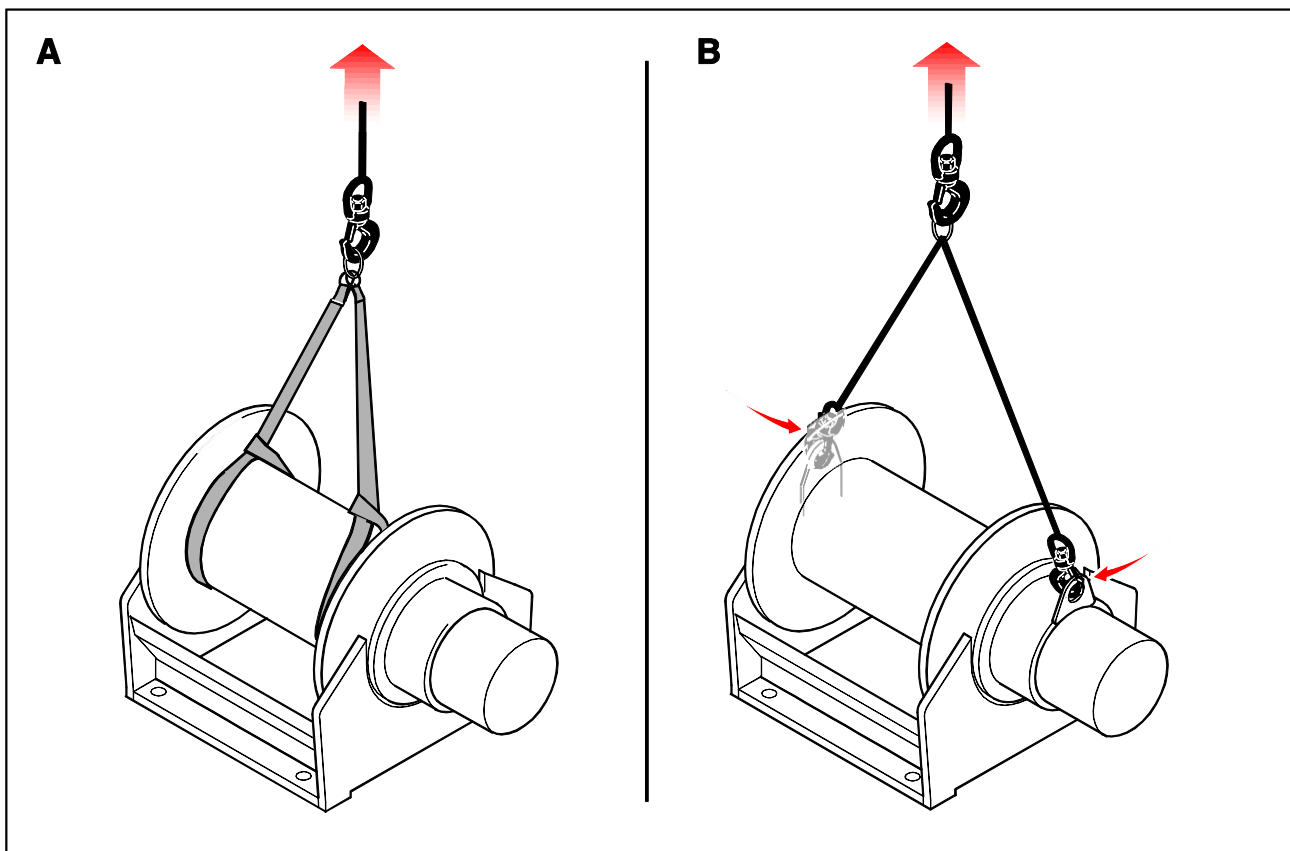

4.4 – Assembly on base plate

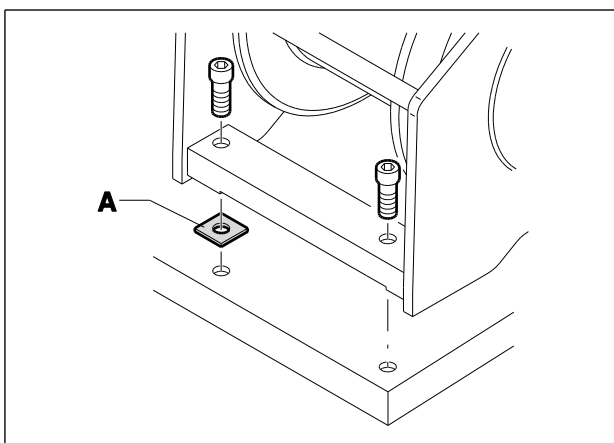

- Make sure that the surface the winch will be fastened to is rigid enough and even.
- Place the winch on the surface and check that the fastening plates lie perfectly flat on the fastening surface.
- If one of the 4 weight bearing points of application is raised, insert a shim "A" to balance the unit and avoid causing the unit undue tension during screw tightening.
- Tighten the screws with the correct tightening torque, see section "2.11-Technical data".

4.5 – Installation

4.5.1 – Warnings



Winch installation and post-installation checks must be carried out according to the applicable rules in the country where the machine is used.

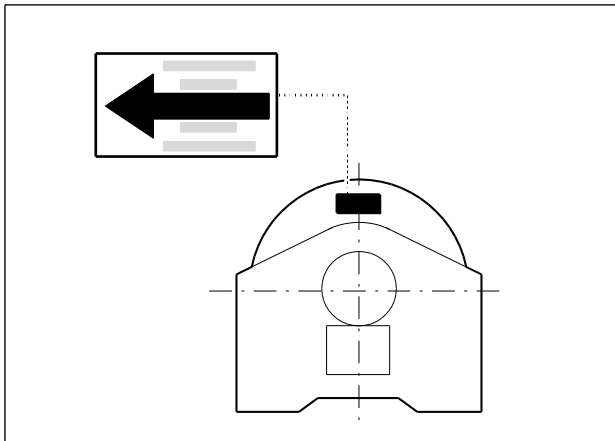

Before assembly, make sure the winding direction of the rope corresponds to the one indicated by the arrow applied on the winch (fig. 4.5.1).

The winch can be mounted with the fastening surfaces facing downwards, upwards or in any other position between the two.

4.5.2 – Hydraulic system

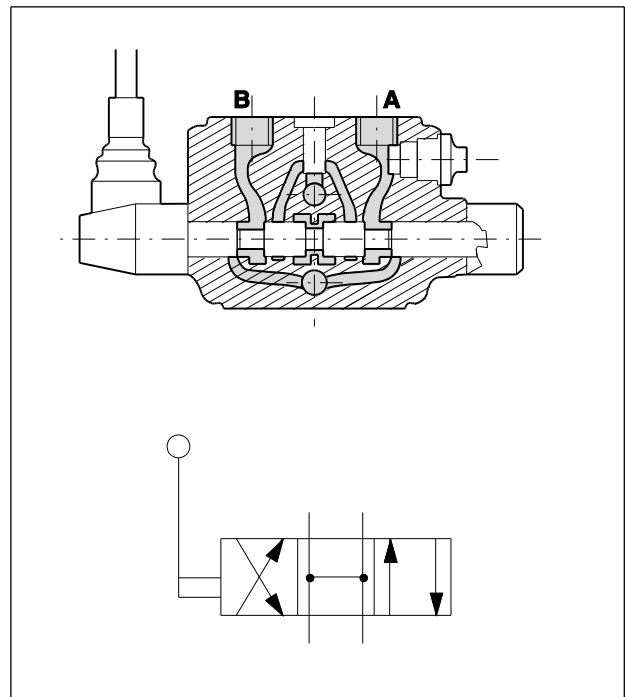

The distributor, therefore, must have an open centre (fig. 4.5.2) with an "H" configuration.

If the distributor presents a plurality of elements, connect the winch to the last element closest to the outfeed side. Connect the delivery opening of the element to the winch motor in position "V2".

The hydraulic system must meet the applicable rules and realised with proper hoses, filters and valves.

4.6 – Hydraulic diagram

- Hydraulic diagram for winch without accessories

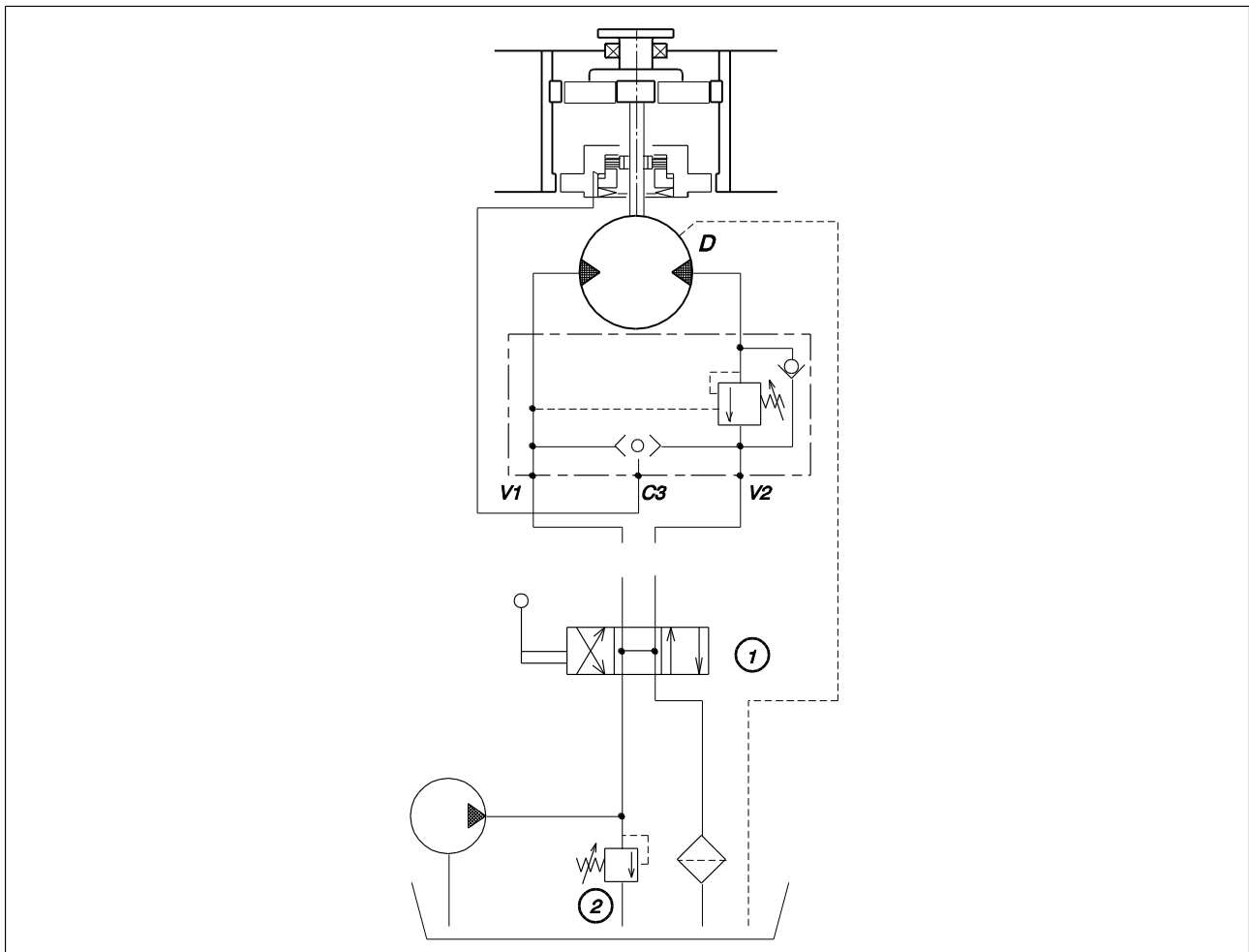

V1 = Lowering line
V2 = Hoisting line
C3 = Connection to brake

1 = Open centre valve
2 = Relief valve
D = Connection of drainage unit

- Hydraulic diagram for winch with limit switch-electrical cable press (if present)

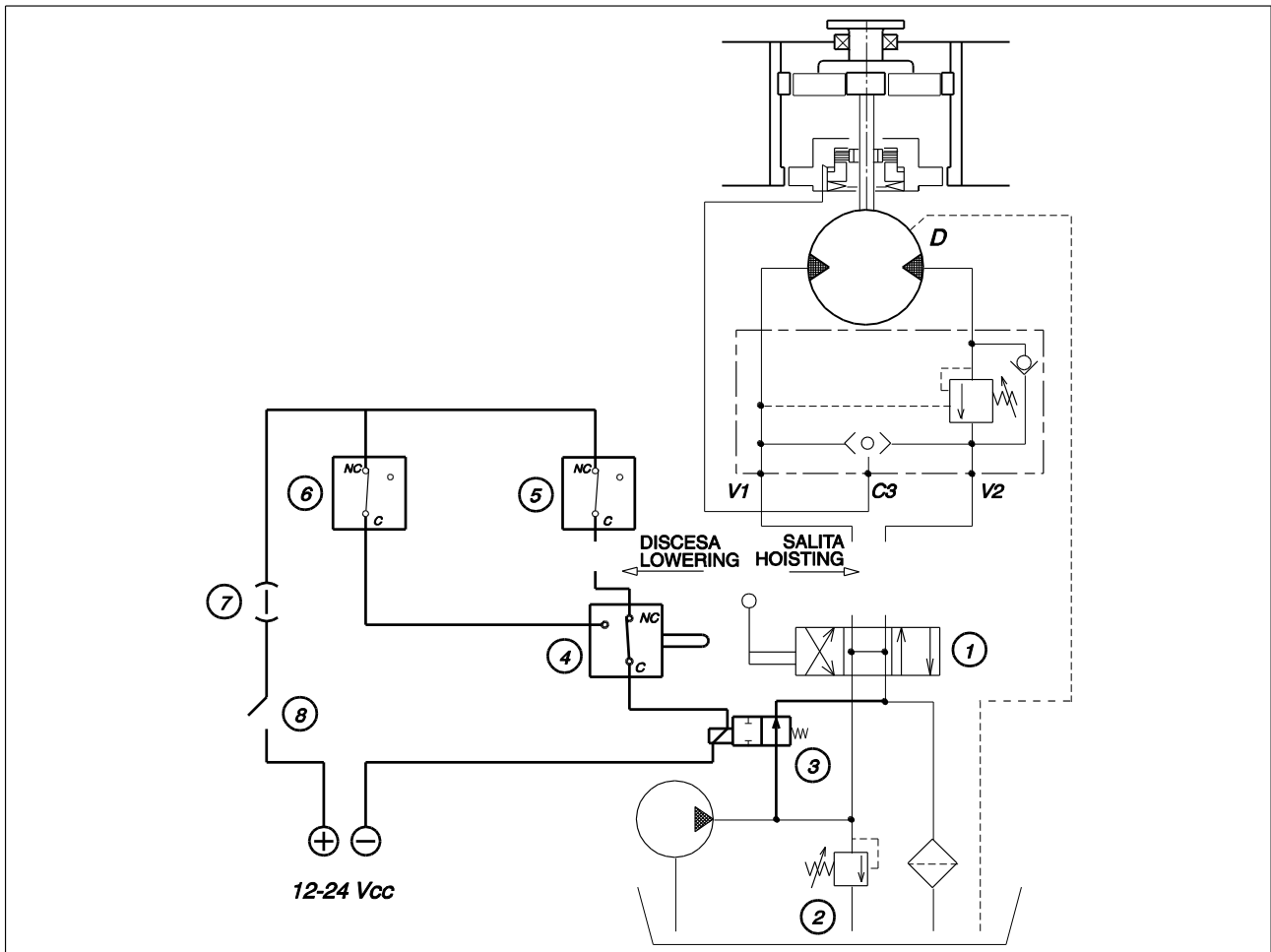

- | | | | |
|-----------|-------------------------------|----------|---|
| V1 | = Lowering line | 3 | = Discharge activation solenoid valve n.o |
| V2 | = Hoisting line | 4 | = Resetting microswitch |
| C3 | = Connection to brake | 5 | = Upwards stroke limit micro-switch |
| D | = Connection of drainage unit | 6 | = Downwards stroke limit micro-switch |
| 1 | = Open centre valve | 7 | = Fuse |
| 2 | = Relief valve | 8 | = Limit switch activation key |

- Hydraulic diagram for winch with cable press - hydraulic limit switch (if present)

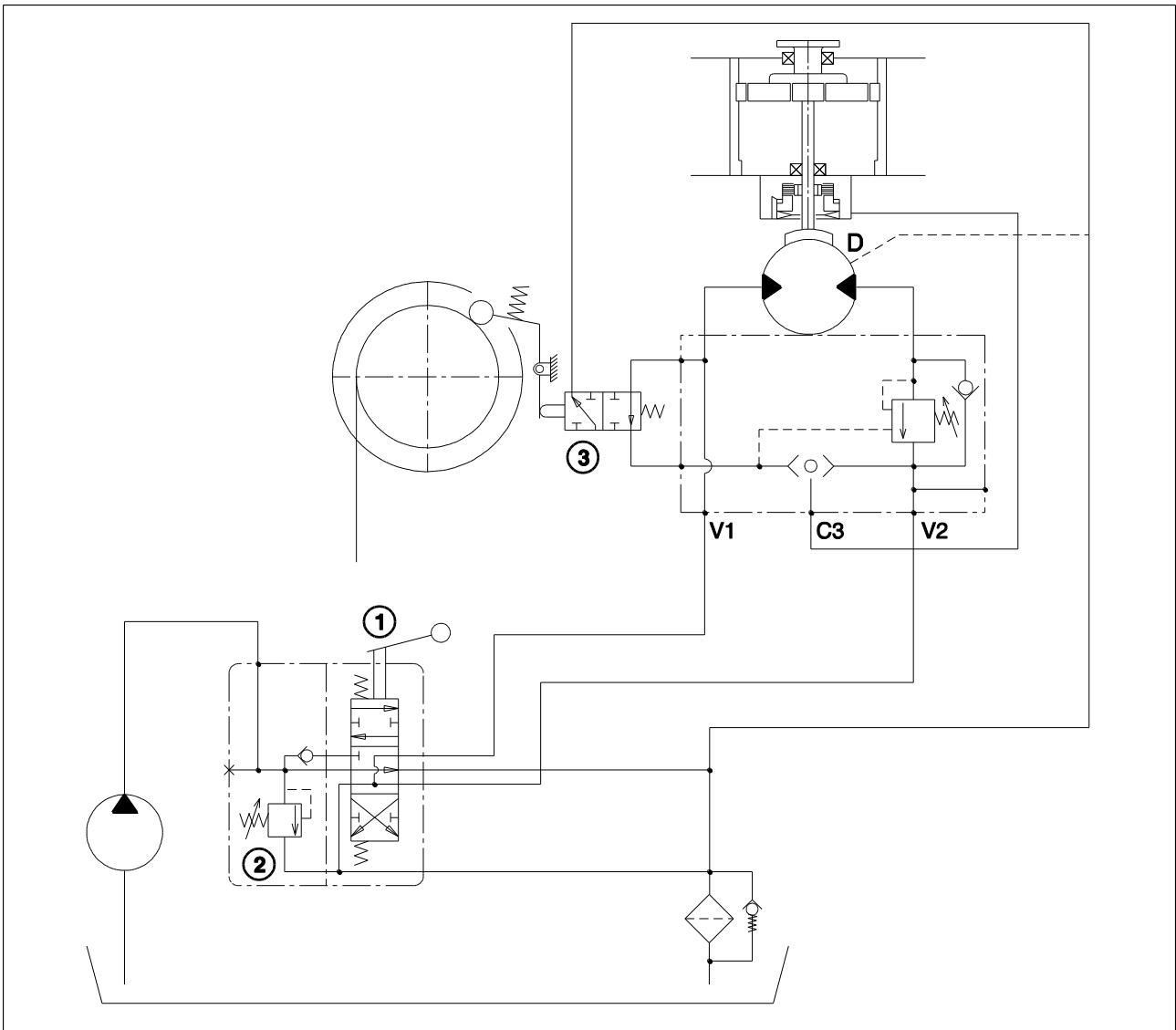

V1 = Lowering line

V2 = Hoisting line

C3 = Connection to brake

D = Connection of drainage unit

1 = Open centre valve

2 = Relief valve

3 = Lower stroke limit hydraulic valve

4.7 – Checks

- Check the pressure in the return line of the circuit

This measurement should be made by disconnecting the two tubes from the valve and connecting them with a “T” connection that may be linked to a pressure gauge with a maximum scale of 60 bar.

i Information

This counterpressure must be between 5 and 1 bar.



Counter-pressure values higher than 5 bar dangerously limit the braking torque, and values lower than 1 bar could cause an insufficient motor power supply.

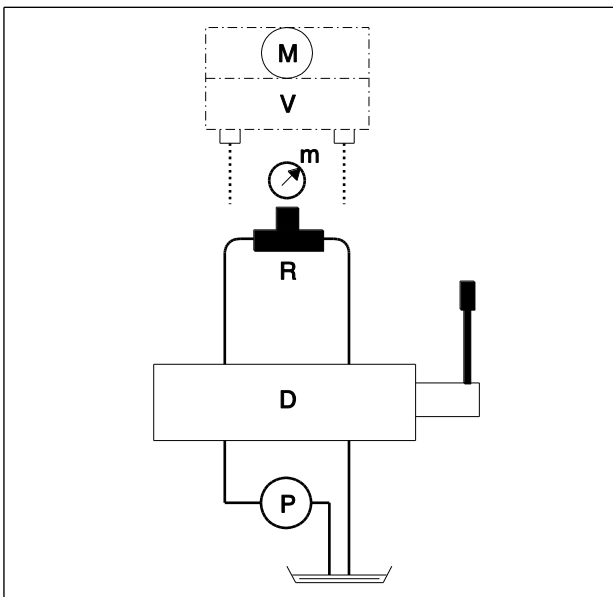

D = Distributor
M = Motor
V = Valve
m = Pressure gauge
P = Pump
R = “T” connection

- Make sure the control distributor has the gate open

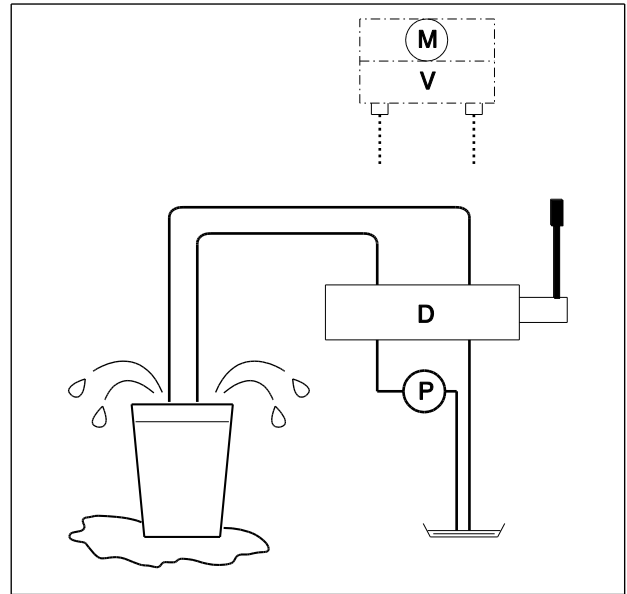

D = Distributor
M = Motor
V = Valve
P = Pump

If you do not have sure indications you may proceed as follows:

- disconnect the tubes from the valve and place their ends in a container with a sufficiently large capacity; start the pump while keeping the distributor in the center.

- If the two tubes do not release oil into the container the distributor has the **gate closed**; if instead the two tubes release oil, the **gate is open**.



Make sure the oil flow does not cause the container to overflow and as a consequence waste oil as well as releasing polluting substances into the environment: if there is a risk of this occurring, interrupt the test immediately and resume it only after having replaced the container with a larger one.

i Information

Do not waste drain oil into the environment but collect it and send it to authorized centres for disposal.

4.8 – Cable mounting

- Installing cable with thimble



The winding direction of the rope must correspond to the drum rotation direction indicated by the arrow.
Make sure that the emergency switch is working and that a skilled operator is on hand and ready to stop the hoist in the event of entangling or other irregularities that may cause harm to the operator who is in the vicinity of the cable.

If the cable is not sufficiently compact during the initial assembly phase, when it is loaded it may become caught up in the turns below and damaged.

- 1) Introduce the rope end into slot positioned on the drum and then in the pocket "A".
- 2) Fold the rope around the thimble "B". Then secure the rope and thimble in the slot by pulling firmly.

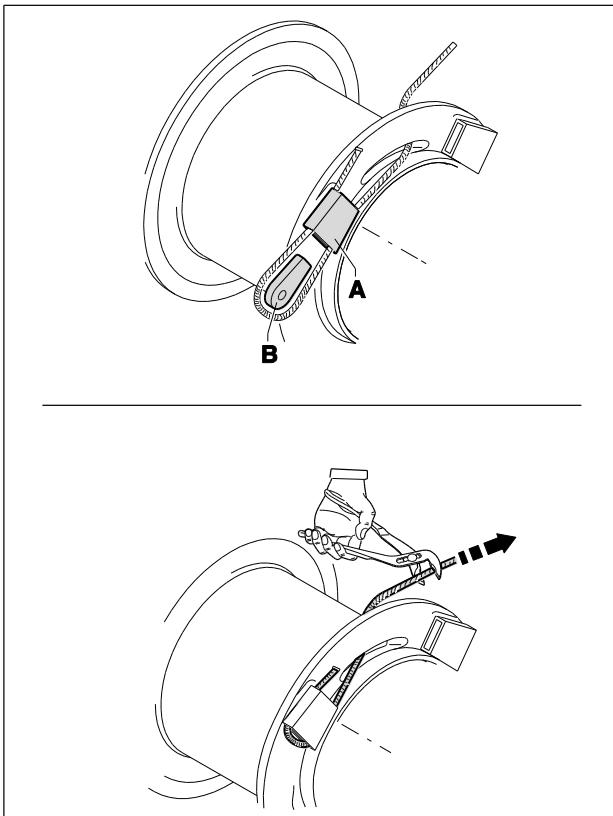

- Installing cable with clamps



The winding direction of the rope must correspond to the drum rotation direction indicated by the arrow.
Make sure that the emergency switch is working and that a skilled operator is on hand and ready to stop the hoist in the event of entangling or other irregularities that may cause harm to the operator who is in the vicinity of the cable.

If the cable is not sufficiently compact during the initial assembly phase, when it is loaded it may become caught up in the turns below and damaged.

- 1) Place the end of the cable in the slot on the edge of the drum and then in the clamps "A".
Minimum protrusion "B" from the last clamp equal to 2 times the \varnothing of the cable.
- 2) Tighten the clamps screws.

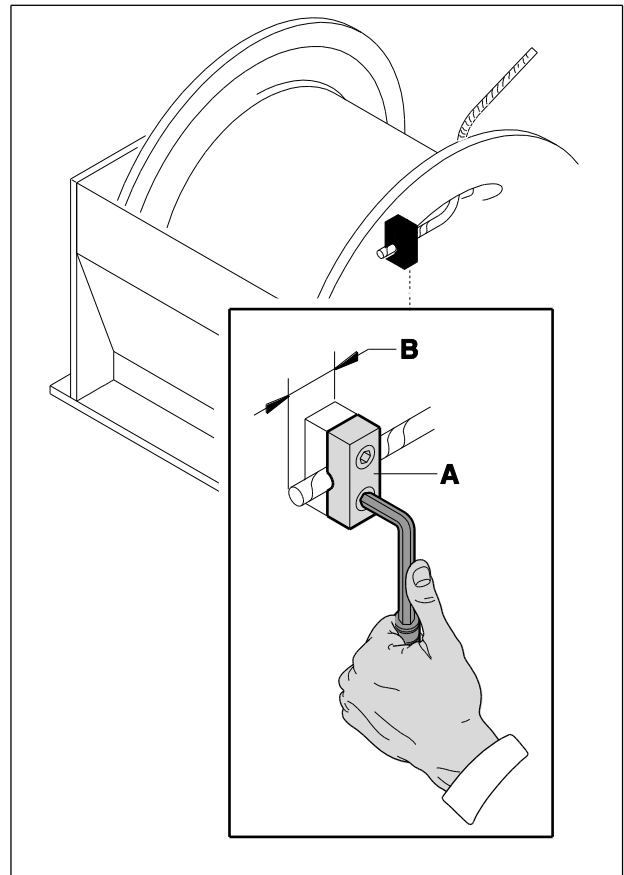

For a correct winding, it is necessary to have a minimum preload of 5% of the breaking force of the rope. The breaking force of the rope depends on the diameter and of the type of the rope and it has to be indicated in the rope certificate.

4.9 – Pulleys

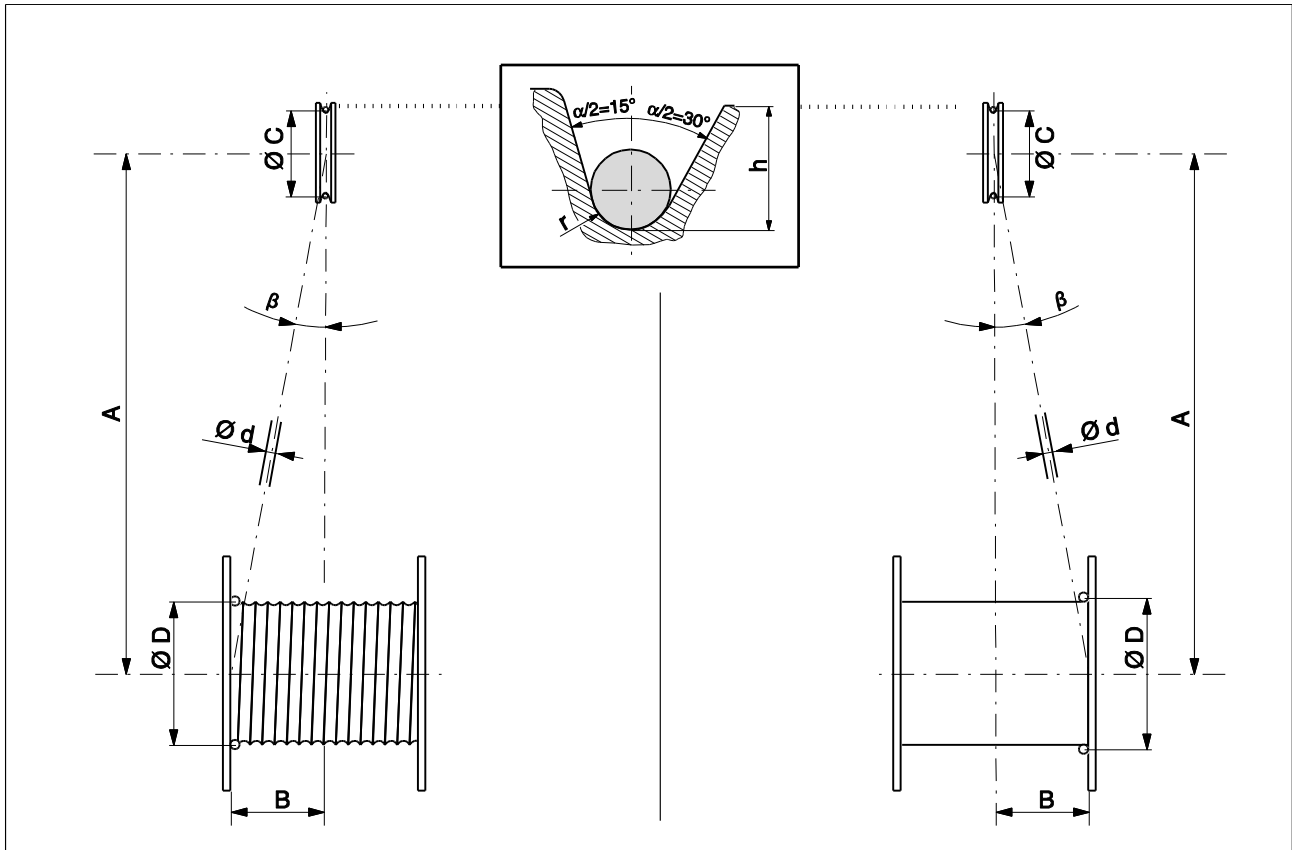

- Legend

- H** = Depth of the sheave groove
- α = Angle between sides of the sheave
- d** = Nominal diameter of the rope
- 1** = Maximum angle " β ":
smooth drum = $1^{\circ}30'$ ($\text{tg } \beta = B/A$)
threaded drum = 2° ($\text{tg } \beta = B/A$)
- 2** = Groove radius " r " = $0,5375 \times d$
- 3** = Groove minimum height " h " = $2 \times d$
- 4** = Angle between the pulley groove " α " = between 30° and 60° .

- Diameter choice according to gear class

Classification of mechanism	Drums $h_1 = D/d$	Pulleys $h_2 = C/d$
M1	11,2	12,5
M2	12,5	14,0
M3	14,0	16,0
M4	16,0	18,0
M5	18,0	20,0
M6	20,0	22,4
M7	22,4	25,0
M8	25,0	28,0

The size of the return pulley pitch diameter must comply with the standard ISO 4308-1, according to the mechanism classification.

Example:
for mechanism classification M5, the ratio between the pulley pitch diameter and the diameter of the cable must be no lower than 20.

5 – INFORMATION ABOUT ADJUSTMENTS

5.1 – Adjustments

- Calibrating the cable press limit switch (if present)

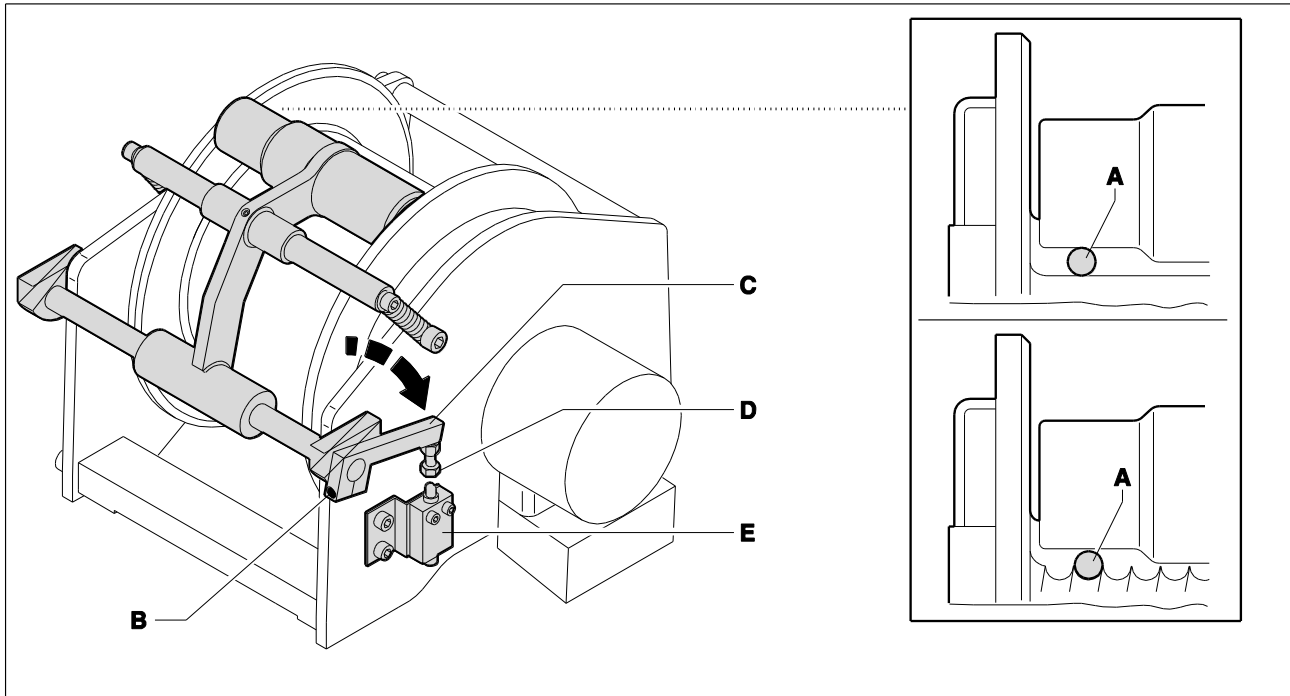

i Information

Carry out the operation with the rope completely unwound.

- 1) Insert a shim "A" with the same diameter of the rope under the roller end.
- 2) Loosen screw "B".
- 3) Turn lever "C" until screw "D" excites microswitch "E".
- 4) Tighten screw "B".

6 – START UP INFORMATION

6.1 – Start up

- Safety instructions



Before the intervention it is necessary to warn, with signs or other suitable means, that it is forbidden to get close and stay in the danger zone due to the presence of suspended loads.

A danger warning plate, notifying the danger constituted by running cables that wrap around pulleys and drum, must be placed on the machine. This prohibit anyone from approaching to the moving parts. This plate has to be reported in the user manual of the crane or of the machinery on which it is mounted.

- Check hoisting part conditions (rope, hook, etc.) before using the winch.
- During start up operations, the operator and any member of the team shall keep a safety distance from the rope, to prevent personal injuries in case of its breakage.
- It is standard practice to carry out the first few operations hoisting a modest load to no more than 1 metre from the ground, in order to check that the lowering operation is controlled.
- Carry out manoeuvres gradually; avoid sudden jerking and load swivelling.

7 – MAINTENANCE INFORMATION

7.1 – Warning



Make sure the machine on which the winch is installed is stopped and cannot be started during maintenance activities.

7.2 – Maintenance schedule

Operation	Frequency			Chap. Of the manual
	8 hours	250 hours	500 hours	
Cable inspection	•			7.3
Oil level check		•		7.4
Cable lubrication		•		7.3
Screws tightness check		•		2.11
Reduction gear oil replacement			•(*)	7.4

(*)Carry out the first replacement after 500 working hours; afterwards, once a year.

7.3 – Cable

- Cable inspection

- Check the condition of the cable carefully, along its entire length.
If it has any dents, crushed sections, bulges or a number of broken strands, it must be replaced with a cable with the same specifications and length.
- Replace the cable in the event of a reduction in the rated diameter of at least 10% due to breakage of elementary strands or wear.
- Replace the cable when corrosion or any kind of warping occurs.

- Cable lubrication

Clean the cable thoroughly to remove all traces of dirt, dust and sand.
To reduce corrosion, lubricate the cable with a specific product.

7.4 – Lubrication

7.4.1 – Oil level check and replacement (winches series NP - NPA - A - S - SE - SW - SF)

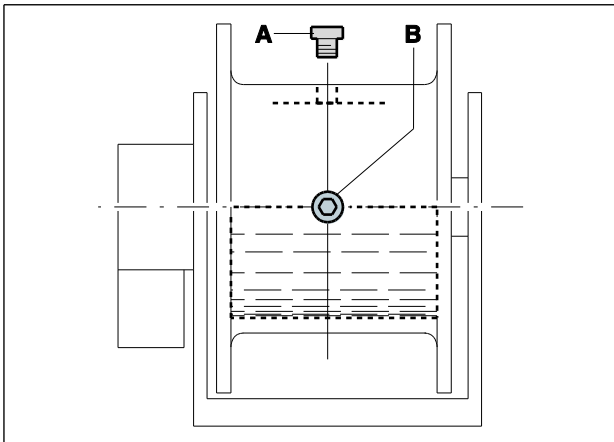

i Information

Do not waste drain oil into the environment but collect it and send it to authorized centres for disposal.

Unwind the rope until filling cap "A" and level cap "B" are visible. In case of low oil level, top up through cap "A" hole until oil comes out from cap "B" hole (in horizontal position). For oil type, see par. "Technical data".

In case of oil replacement:

- Put a container under the winch to drain used oil.
- Turn the drum to position the level hole to the lowest position.
- Drain off oil completely.
- Turn the drum to position the level hole on the horizontal axis and the filling hole on top.
- Put oil through the filling hole until it pours out level hole.
- Retighten level cap "B" and filling cap "A".

7.4.2 - Oil level check and replacement (winches series serie SR - SWR - SFR)

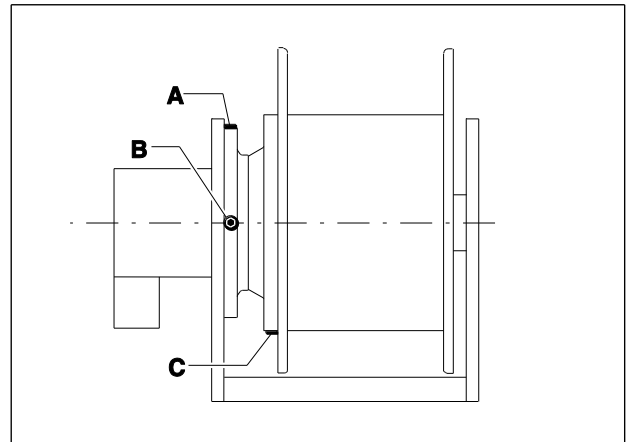

i Information

Do not waste drain oil into the environment but collect it and send it to authorized centres for disposal.

In case of low oil level, top up through cap "A" hole until oil comes out from cap "B" hole (in horizontal position). For oil type, see par. "Technical data".

In case of oil replacement:

- Put a container under the winch to drain used oil.
- Rotate the drum to position the oil drainage hole "C" at the lowest position.
- Drain off oil completely.
- Close the drainage hole "C" with the relevant cap.
- Put oil through the filling hole until it pours out level hole.
- Retighten level cap "B" and filling cap "A".

7.4.3 - Oil level check and replacement (winches series S - SE)

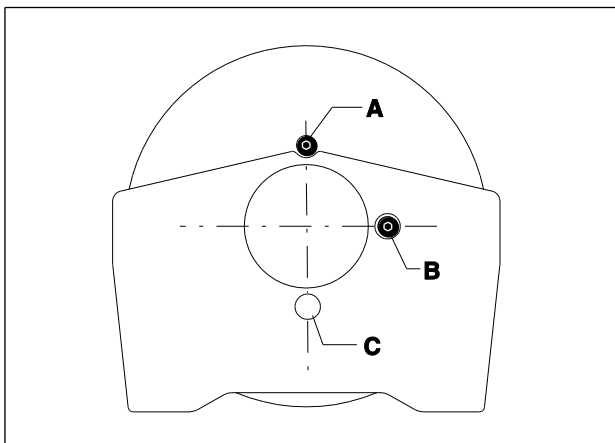

i Information

Do not waste drain oil into the environment but collect it and send it to authorized centres for disposal.

In case of low oil level, top up through plug "A" hole until oil comes out from plug "B" hole (in horizontal position). For oil type, see par. "Technical data".

In case of oil replacement:

- Put a container under the winch to drain used oil.
- Turn the drum to position the level hole to the lowest position "C".
- Drain off oil completely.
- Turn the drum to position the level plug "B" hole on the horizontal axis and the filling plug "A" hole on top.
- Put oil through the filling hole until it pours out level hole.
- Retighten level plug "B" and the filling cap "A".

7.4.4 - Oil level check and replacement (winches series SRD - SWD - WDD)

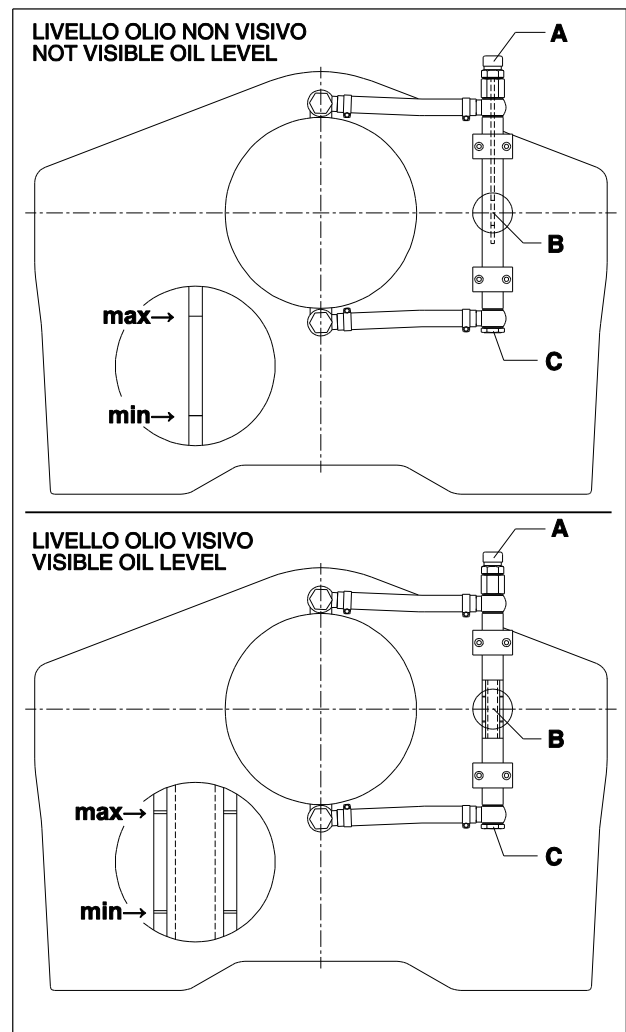

i Information

Do not waste drain oil into the environment but collect it and send it to authorized centres for disposal.

In case of low oil level, top up through plug "A" hole until oil comes the level "B", between min-max indicators. For oil type, see par. "Technical data".

In case of oil replacement:

- Put a container under the winch to drain used oil.
- Remove the plug "C" and drain off oil completely.
- Retighten plug "C".
- Put oil through the filling hole "A" until it reaches the level "B", between min-max indicators.
- Retighten level plug "A".

7.4.5 – Gearbox lubrication grease (winches series P)

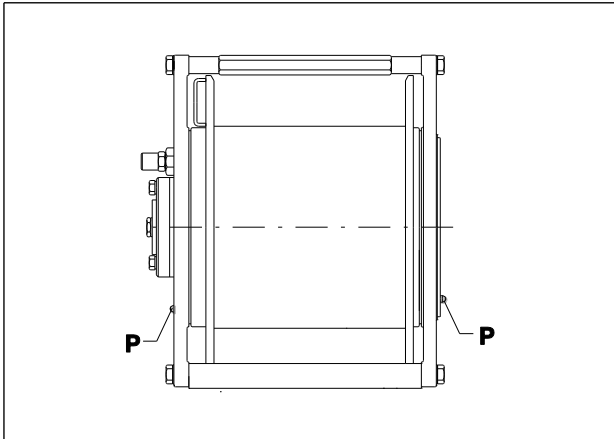

The winch must be greased on the gears mounted inside the drum and on the drum guide rings.
For the lubrication, use lithium grease for gears Renbrand EP/2 - Q8 or equivalents. Grease the internal parts of the drum using the lubricators located on the supports "P" every 250 hours of operation.

7.5 – Cleaning operations



Clean the winch with products meeting the applicable laws. When washing with liquid under pressure do not direct the jet on electrical equipment to avoid damage.

7.6 – Scrapping and disposal

The machine dismantlement must be entrusted to technically qualified personnel specialising in similar operations and with the necessary hydraulic and mechanical abilities. Components shall be separated according to the materials they are composed of and sent to the authorised disposal centres. With reference to WEEE directives (Waste from Electrical and Electronic Equipment), the electric and electronic parts, marked with the relative symbol, must be disposed of via specific authorized collection centres.

8 – PROBLEMS AND SOLUTIONS

8.1 – Troubleshooting

In the event of the winch malfunctioning, please refer to the table below to identify the cause of the problem and possible remedy.

If the problem persists refer to a manufacturer's authorized workshop.

Fault	Possible cause	Remedy
Noises in the hydraulic circuit	Presence of air in the circuit	Purge the circuit
Noises during hoisting accompanied by jerky rotation	Insufficient circulation of oil in the circuit	Operate the hoist with gradually increasing loads until it turns regularly and the noise disappears. If this condition occurs increase the quantity of oil in circulation. If this is not possible, contact Manufacturer Technical Office ATTENTION!!! The insufficient circulation might be caused by a prolonged choking of the oil flow by the operator manoeuvring the lever of the distributor. This operation is dangerous.
The load being lowered tends to fall	Impurities in the valve	Remove the valve and clean it with compressed air and naphtha Check the cartridge of the circuit filter and replace it if necessary
	Cable wound in opposite direction to that indicated by the arrows	Wind the cable in the direction indicated by the arrows (see para. 4.5).
With the distributor set in the center the load tends to go down	Excessively high counterpressure	Connect the drain of the motor directly to the tank
	Brake springs are broken	Replace springs
The hoist cannot lift the load	Insufficient pressure in the hydraulic circuit	Make sure the maximum-load valve on the control distributor is set correctly
	Damaged motor	Check the drainage of the motor If the flow of oil exceeds 1 l per min., replace the motor

9 – PARTS REPLACEMENT

9.1 – Cable replacement

The cable must always be replaced when:

- it has a significant number of broken strands (approximately 10%);
- its is permanently warped (reduction in the section, dented, squashed, etc.);
- the lead coating on the cable lug is damaged.

- Removing cable with thimble

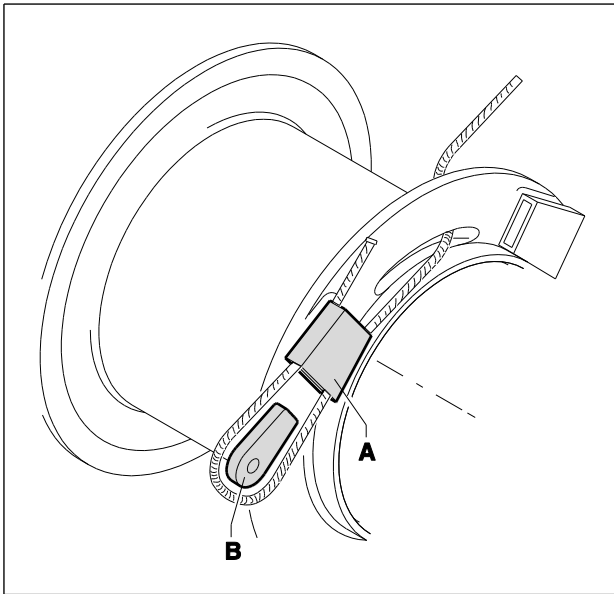

- 1) Completely unwind the rope.
- 2) Extract the rope and the thimble "B" from the pocket "A".
- 3) Slip the rope off.

- Assembly

See para. "Cable mounting".

- Removing cable with clamps

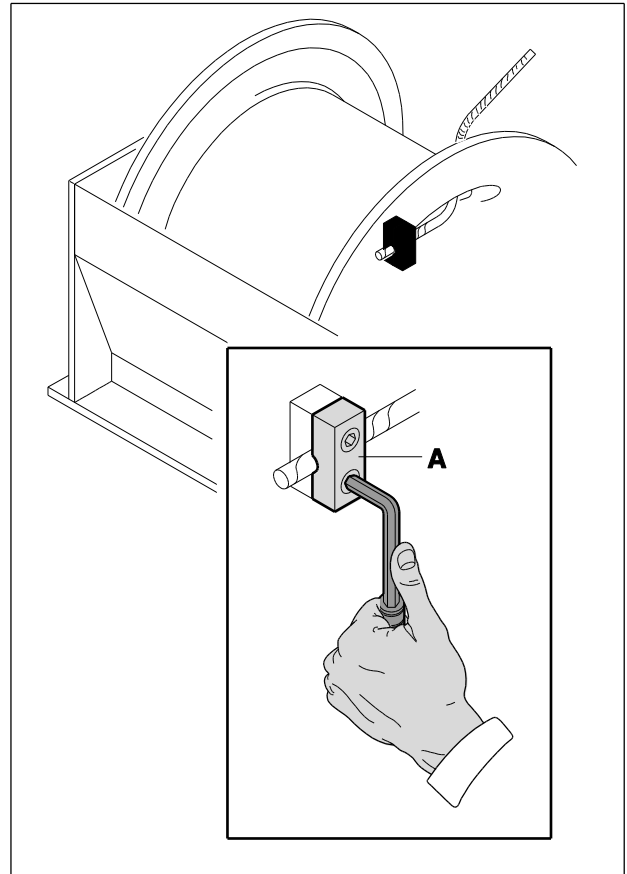

- 1) Completely unwind the cable.
- 2) Loosen the screws of clamps "A".
- 3) Unthread the cable.

10 – ANALYSIS OF THE RESIDUAL RISKS

Note	Directive 2006/42/CE Attached I	Description	Comment
19	1.3.4	Risks due to surfaces, edges or angles	To be understood by the customer during installation operator protection from risks due to surface edges or corners
22	1.3.7	Risks related to moving parts	Are to be considered by the customer to protect the operator from the potential risks related to moving parts
23	1.3.8	Choice of protection against risks related to moving parts	Are to be considered by the customer to protect the operator from the potential risks related to moving parts
25	1.4.1	General requirements for guards and protection devices	Are to be understood by the customer the choice of the requirements for guards and protection devices
26	1.4.2.1	Fixed guards	Are to be understood by the customer the implementation of any fixed guards
28	1.4.2.3	Adjustable guards restricting access	Are to be understood by the customer any adjustable guards restricting access
29	1.4.3	Special requirements for protective devices	Are to be understood by the customer the choice of the special requirements for protection devices

11 – NOTES